

ENGINEERING SPECIFICATION X 1210

doc.no.

reg.no.

CN 070/03005/523

distribution

CONTENTS

<u>CHAPTER</u>		<u>PAGE</u>
1	<u>GENERAL DESCRIPTION</u>	
1.1	Functional description	1-1
1.2	Physical description	1-1
2	<u>PERFORMANCE CHARACTERISTICS</u>	
2.1	General	2-1
2.2	Recording	2-1
2.3	Format	2-1
2.4	Processing speed	2-3
2.5	Reliability	2-3
3	<u>INTERFACES</u>	
3.1	Power interface	3-1
3.2	Signal interface	3-2
3.3	Connectors	3-6
4	<u>OPERATION</u>	
4.1	General	4-1
4.2	Start/stop button/indicator	4-1
4.3	Cartridge exchange indicator	4-1
4.4	Fault indicator	4-2
4.5	Start and stop times	4-2
5	<u>TECHNICAL CHARACTERISTICS</u>	
5.1	Physical description	5-1
5.2	Environmental conditions	5-2
5.3	Mechanical description	5-4
5.4	Electrical description	5-4
5.5	Maintenance	5-5

All rights strictly reserved. Reproduction or issue in third party in any form without written permission is not permitted without written authority from the proprietors.

Property of
Eigendom van:
N.V. PHILIPS - ELECTROLOGICA
Apeldoorn
Nederland

Alle rechten uitdrukkelijk voorbehouden.
Vernieuwingsrechten of mededeling aan
derden in welke vorm ook, is zonder
schriftelijke toestemming van eigenares
niet geoorloofd.

status		supers.doc.no.	dept Prod.planning
REVISION	A		author H.v.Maastricht
REV	B	N.V. PHILIPS - ELECTROLOGICA I.G. Peripheral Equipment	date 70-03-12
			page 0-1

ENGINEERING SPECIFICATIONS X 1210

doc.no.

reg.no.

CN070/03005/523

distribution

CONTENTS

<u>CHAPTER</u>		<u>PAGE</u>
6.	<u>OPTIONS</u>	6-1
6.1	General	6-1
6.2	Mono disk cartridge	6-2
6.3	Rack unit slides	6-11
6.4	Rack unit cable guide	6-13
6.5	Power supply unit	6-15
6.6	Tester module	6-27
6.7	Mono disk exerciser	6-32
6.8	C.E. cartridge	6-35
6.9	Handbook	6-37

7.	<u>APPLICABLE DOCUMENTS</u>	
7.1	Safety requirements	7.1
7.2	Interference	7.1

All rights strictly reserved. Reproduction or issue to third parties in any form whatever is not permitted without written authority from the proprietors.

Eigendom van:
N.V. PHILIPS - ELECTROLOGICA
Apeldoorn
Nederland

Alle rechten uitdrukkelijk voorbehouden. Vermenigvuldiging of mededeling aan derden, in welke vorm ook, is zonder schriftelijke toestemming van eigenares niet geoorloofd.

status	supers doc.no.	dept	Prod. planning
		author	
N.V. PHILIPS - ELECTROLOGICA I.G. Peripheral Equipment		date	71-07-09
		page	0-2

ENGINEERING SPECIFICATION X 1210

doc.no.

reg.no.

CN 070/03005/523

distribution

All rights strictly reserved. Reproduction or issue in any form without written authority from the proprietors.

1 (GENERAL DESCRIPTION

1.1 Functional description

The X 1210 is small random access mass storage device. The X 1210 disk drive unit functions with a Philips XMX 1424 or XMX 1416 magnetic disk cartridge. The storage medium is an industry standard 14 inch diameter single disk, coated on both sides with a magnetic oxide layer. The disk is permanently enclosed in the cartridge for maximum protection against contamination and damage. The cartridge and the recording format is not compatible to other storage systems. The X 1210 will be operated in conjunction with a remotely located power supply and a control unit. The power supply furnishes the A.C. and D.C. voltages required for all electrical circuits. The control unit, electrically between the I/O channel of a processor and the disk drive unit, controls the operation of the X 1210. Neither power supply nor control unit are supplied with the basic disk drive unit. The X 1210 is intended for use as a disk file with terminals, office machines and small to medium size computing systems, requiring direct access to a 2.5 Mbyte file with an average access time (latency and head positioning time) of 137,5 msec. The X 1210 makes also possible a flexible building block system which can be tailored to the customer requirements.

Eigendom van: N.V. PHILIPS - ELECTROLOGICA Apeldoorn
Property of: N.V. PHILIPS - ELECTROLOGICA Nederland

Alle rechten uitsluitend voorbehouden. Vermenigvuldiging of mededeling aan derden, in welke vorm ook, is zonder schriftelijke toestemming van eigenaars niet geoorloofd.

status		supers doc.no.	dept Prod.planning
REV	B		author H.v.Maastricht
N.V. PHILIPS - ELECTROLOGICA I.G. Peripheral Equipment			date 70-03-12
			page 1-1

ENGINEERING SPECIFICATION X 1210

doc.no.

reg.no.

CN 070/03005/523

distribution

All rights strictly reserved. Reproduction or issue to third parties in any form whatever is not permitted without written authority from the proprietors.

Eigendom van:
N.V. PHILIPS - ELECTROLOGICA
Apeldoorn
Property of
Nederlands

Alle rechten uitdrukkelijk voorbehouden. Vermenigvuldiging of mededeling aan derden, in welke vorm ook, is zonder schriftelijke toestemming van eigenares niet geoorloofd.

1.2 Physical description

The X 1210 disk drive unit contains all the mechanisms functional to the unit performance plus the electrical hardware such as switches and indicators required for fundamental control. The main features of the disk drive unit, however, are design simplicity and operational reliability.

The X 1210 is designed as a rack mounted device, intended for installation in a standard RETMA 19 inch wide and 30 inch deep rack. When mounted in the rack the disk drive unit is mounted on slides and is completely accessible from the front. The unit can be installed in and removed from the rack without using special tools. For normal cartridge loading, the unit shall be withdrawn from the front of the rack. For maintenance purposes the unit can be drawn completely out of the rack providing full accessibility. Figure 1(1) shows the physical appearance of the X 1210 disk drive unit.

status		supers doc.no.	dept Prod.planning
REV	B		autho H.v.Maastricht
N.V. PHILIPS - ELECTROLOGICA I.G. Peripheral Equipment			date 70-03-12
			page 1-2

ENGINEERING SPECIFICATION X 1210

doc.no.
 reg.no. CN 070/03005/523
 distribution

All rights strictly reserved. Reproduction or issue to third parties in any form whatsoever is not permitted without written authority from the proprietors.

Eigendom van: Property of
 N.V. PHILIPS - ELECTROLOGICA
 Apeldoorn Nederland

Alle rechten uitdrukkelijk voorbehouden. Vermenigvuldiging of mededeeling aan derden, in welke vorm ook, is zonder schriftelijke toestemming van eigenares niet geoorloofd.

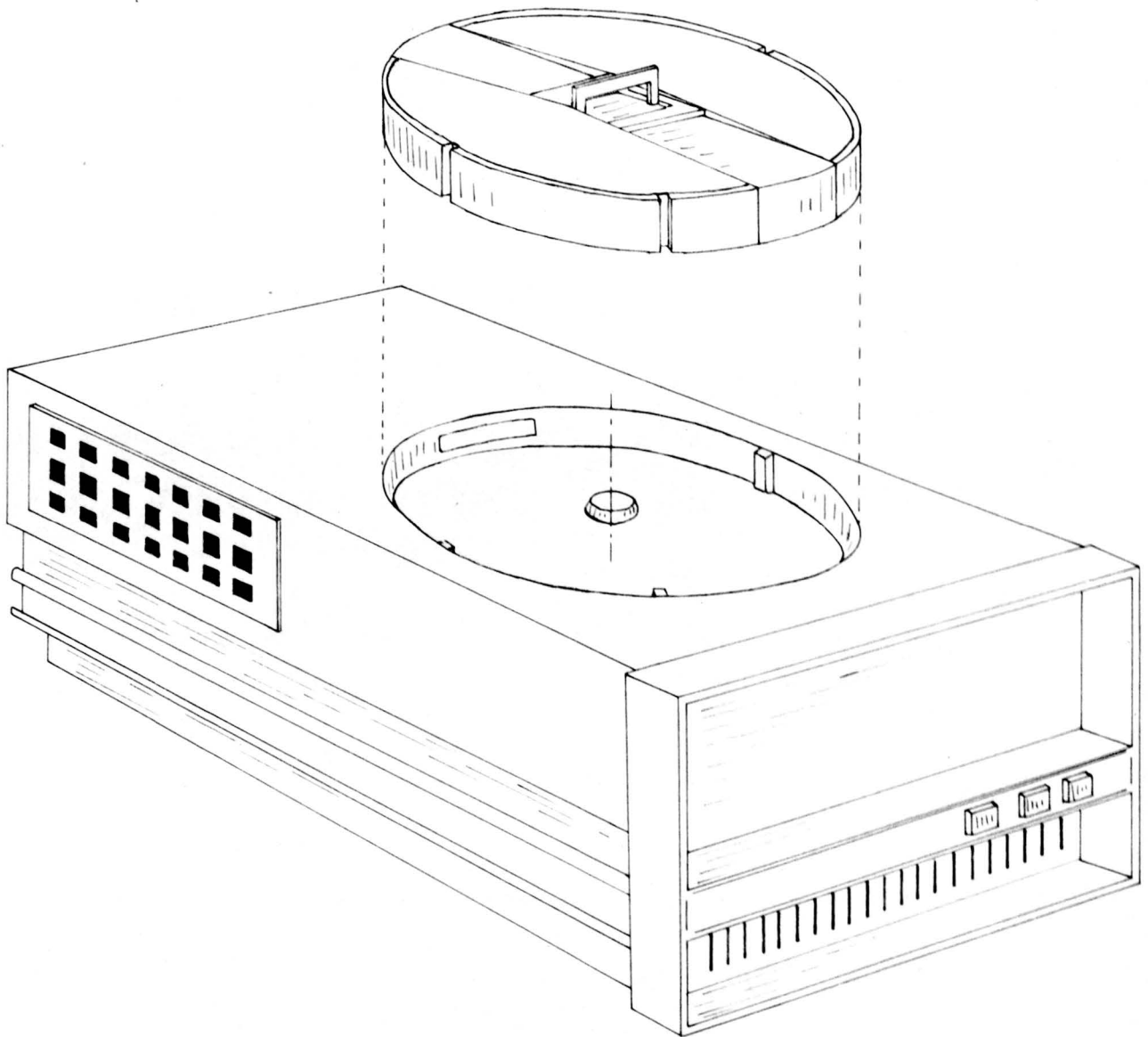

X 1210 DISK DRIVE UNIT AND CARTRIDGE

FIGURE 1.(1)

status		supers doc.no.	dept Prod.planning
REV	B		author H.v.Maastricht
N.V. PHILIPS - ELECTROLOGICA I.G. Peripheral Equipment			date 70-03-12
			page 1-3

2 PERFORMANCE CHARACTERISTICS

2.1 General

In the following paragraphs the characteristics of the X 1210 disk drive unit are described. The unit is compatible with other X 1210 systems. No compatibility with disk drive units of other makes exists.

2.2 Recording

The recording is as follows:

- recording mode : double frequency
- recording medium : standard 14" magnetic oxide disk
- recording density: 1505 bpi (outer track) nominal
2200 bpi (inner track) nominal

2.3 Format

The formatting, when using a Philips cartridge, is as follows:

- recording surfaces: 2
- tracks per surface: 200 + 4 (spare)
- track numbering : 000 through 203 from outside to inside
- track diameter : reference track no.203 at 230,000 mm nominal
- track spacing : 0,262 mm nominal (positioner pitch)
- index marking : 1 per revolution
- storage capacity : under worst case conditions the physical data capacity shall be approx. 3,1 Mbyte (eight bits). However, data checking requirements and inter-record gaps reduce the total capacity, depending on the control unit and the number of records per track. Therefore the maximum capacity will be approx. 2,9 Mbyte on the basis of one data record per track. The storage capacity (exclusive spare tracks) when using a Philips XMX 1416 cartridge on the basis of 256 bytes per sector is shown in table II. When using a Philips XMX 1424 cartridge the storage capacity (exclusive spare tracks) based on 210 16 bit words per sector is given in table I.
- read/write checking: by control unit

All rights strictly reserved. Reproduction or issue to third parties in any form whatever is not permitted without written authority from the proprietors.

Eigendom van: N.V. PHILIPS - ELECTROLOGICA Apeldoorn
Property of: N.V. PHILIPS - ELECTROLOGICA Nederland

Alle rechten uitsluitend voorbehouden. Vermenigvuldiging of mededeling aan derden, in welke vorm ook, is zonder schriftelijke toestemming van eigenaars niet geoorloofd.

status		supers doc.no.	dept Prod.planning
REV.	B		author H.v.Maastricht
REV.	D	N.V. PHILIPS - ELECTROLOGICA	
		I.G. Peripheral Equipment	
		date 70-03-12	page 2-1

ENGINEERING SPECIFICATION X 1210

doc.no.

reg.no.
CN 070/03005/523

distribution

T A B L E I
(16-sectors)

ON LINE STORAGE CAPACITY						
	per word	per sector	per track	per cylinder	per surface	per cartridge
bits	16	3.360	53.760	107.520	10.752.000	21.504.000
words	-	210	3.360	6.720	672.000	1.344.000
sectors	-	-	16	32	3.200	6.400
tracks	-	-	-	2	200	400
cylinders	-	-	-	-	-	200
surfaces	-	-	-	-	-	2

T A B L E II
(24-sectors)

ON LINE STORAGE CAPACITY						
	per character	per sector	per track	per cylinder	per surface	per cartridge
bits	8	2.048	49.152	98.304	9.830.400	19.660.800
characters	-	256	6.144	12.288	1.228.800	2.457.600
sectors	-	-	24	48	4.800	9.600
tracks	-	-	-	2	200	400
cylinders	-	-	-	-	-	200
surfaces	-	-	-	-	-	2

status		supers doc.no.	dept Prod.planning
REV.	B		author H.v.Maastricht
N.V. PHILIPS - ELECTROLOGICA I.G. Peripheral Equipment			date 70-03-12
			page 2-2

ENGINEERING SPECIFICATION X 1210

doc.no.
reg.no. CN 070/03005/523
distribution

All rights strictly reserved. Reproduction or issue in any form without written authority from the proprietors.

2.5.2 (continued)

b. Read operation

Definition - An irrecoverable read error is one which cannot be recovered after three attempts at reading the record, providing the previous write operation has been verified.
Error rate - The irrecoverable read error rate will be better than 10^{-12} bits.

2.5.3 Head positioning error

The access mechanism positioning error rate shall be less than one error per 10^5 seek executions.

2.5.4 Other errors

a. Environmental errors

When operating at low effective data transfer rates, i.e., random access of single short records, the effective error rate may be expected to exceed the above limits due to external environmental interference. The resulting recoverable read error rate will be less than one error in eight hours of operation.

b. Media errors

Errors due to defects in the media or included foreign particles shall not be counted in error rate computations.

c. Remaining bit errors

When a bit is found to be in error in a record, all remaining bits in error within that record will not be counted when computing the error rate.

2.5.5 Data security

Under no circumstance of normal control unit I/O operation it shall be possible to write a pattern not corresponding to that on the write data lines. It is only possible to alter the recorded bit pattern when the disk drive unit signifies an ON CYLINDER status, and then only upon specific disk drive unit selection.

2.5.6 Mean time between interruptions

Definition - The mean time between interruptions is defined as the time between FAULT conditions (indicated by FAULT indicator on the operator's panel and the UNIT UNSAFE interface signal).
MTBI - The MTBI shall be not less than 250 operating hours as indicated by the elapsed time meter.

Note: The MTBI applies only to unit interruptions. Interruptions caused by external sources, such as control unit, power supply etc. may not be counted.

Eigendom van: N.V. PHILIPS - ELECTROLOGICA
Apeidoorn
Property of: N.V. PHILIPS - ELECTROLOGICA
Nederland

Alle rechten uitsluitend voorbehouden. Vermeerdering of verspreiding van de inhoud in welke vorm ook is zonder schriftelijke toestemming van eigenaars niet geoorloofd.

status		supers doc.no.	dept
REV.	B		Prod.planning
			author H.v.Maastricht
N.V. PHILIPS - ELECTROLOGICA I.G. Peripheral Equipment			date 70-03-12
			page 2-4

All rights strictly reserved. Reproduction or translation in any form whatsoever is not permitted without written authority from the proprietors.

Property of
Eigendom van
N.V. PHILIPS - ELECTROLOGICA
Apeldoorn Nederland

Alle rechten uitsluitend voorbehouden.
Vernietigdiging of mededeling aan
derden, in welke vorm ook, is zonder
schriftelijke toestemming van eigenaars
niet geoorloofd.

2.5.7 Mean time between failure

Definition - The MTBF is expressed by the following equation:

$$MTBF = \frac{\text{No. of operating hours}}{\text{No. of equipment failures}}$$

Operating hours means total time, elapsed time meter hours less any maintenance time, recorded on the elapsed time meter. Equipment failures means any stoppage or substandard performance of the equipment because of equipment malfunction and requiring un-scheduled maintenance, excluding stoppages or substandard performance caused by operator error, adverse environment, power failure, control unit failure or other failure not caused by the equipment. Essentially the term equipment failure, implies that emergency maintenance is required because of hardware failure or substandard performance.

MTBF - Following an initial period of 200 hours, the MTBF will exceed 1000 hours for units manufactured in the first year of production and 1500 hours for units manufactured in the second year. For units manufactured after the second year, the MTBF will exceed 1800 hours.

2.5.8 Mean time to repair

Definition - The MTTR is the average time an adequately trained and competent serviceman will need to diagnose and correct an equipment malfunction.

MTTR - The MTTR following the initial 200 operating hours will be less than two man-hours.

2.5.9 Preventive maintenance time

Definition - The routine preventive maintenance will be performed by suitably trained and competent customer personnel or serviceman. The schedule for preventive maintenance will be based on procedures recommended by IGPE.

PMT - The routine scheduled preventive maintenance time will not exceed one man-hour per 500 operating hours.

2.5.10 Service life

Definition - The service life is the number of operating hours, indicated on the elapsed time meter, before factory overhaul or replacement is required. Repair or replacement of major parts will be permitted during the life time.

Service life - The disk drive unit will be designed and constructed to provide a useful life of five years or 24.000 hours, whichever occurs first.

status		supers doc.no.	dept Prod.planning
REVISION	A		author H.v.Maastricht
REV.	B	N.V. PHILIPS - ELECTROLOGICA I.G. Peripheral Equipment	date 70-03-12
REV.	E		page 2-5

ENGINEERING SPECIFICATION X 1210

doc.no.

reg.no.

ON 070/03005/523

distribution

3 INTERFACES

3.1 Power interface

The disk drive unit shall perform within the performance limits when the following voltages are supplied.

3.1.1 A.C. voltage

Input voltage : 220 Vrms nominal, one phase with safety earth limits for higher voltages than nominal value:

- a. 10% from nominal value
- b. between 10% and 15%, provided that duration is not longer than 10 sec., with a duty cycle of maximum 1 : 20

limits for voltages lower than nominal value:

- a. 10% from nominal value
- b. between 10% and 15%, provided that duration is not longer than 10 sec., with a duty cycle of maximum 1 : 20
- c. any value during maximum 10 msec., with a repetition rate of less than one per sec.

Distortion : maximum linear harmonic distortion 10%

Frequency : 50 Hz nominal
limit $\pm 2\%$, due to possible installation in industrial area.

Input current : approx. 0,6 amps

3.1.2 D.C. voltage

Input voltages: + 5 V ($\pm 5\%$), 2,0 amps

- 12 V ($\pm 5\%$), 0,3 amps

+ 24 V ($\pm 5\%$), 3,3 amps

Note: These A.C. and D.C. voltages will be applied and removed in the proper sequence.

Turn-on overshoot of the D.C. voltages should not exceed 10% of the nominal values. Regulation of these voltages (both RMS and instantaneous noise spikes) must not exceed the tolerances specified above.

All rights strictly reserved. Reproduction or issue to third parties in any form without the prior written permission of the authority from the proprietors.

Eigendom van: N.V. PHILIPS - ELECTROLOGICA Apeldoorn
Property of: N.V. PHILIPS - ELECTROLOGICA Nederland

Alle rechten uitdrukkelijk voorbehouden. Vermenigvuldiging of mededeling aan derden, in welke vorm ook, is zonder schriftelijke toestemming van eigenaars niet geoorloofd.

status		supers doc.no.	dept. Prod. planning
REV.	B _c		author H.v.Maastricht
REV.	E ₂	N.V. PHILIPS - ELECTROLOGICA Peripheral Equipment Division	date 70-03-12
			page 3-1

3.2 Signal interface

3.2.1 General

The signal interface is designed in such a way to allow the use of a simple control unit or a central processor acting as a control unit. In the case of several disk drive units in one system, each unit will be separately connected to the control unit. Therefore selection takes place in the control unit. The interface will allow seek overlap operations.

3.2.2 Input signals

The incoming signals are the following :

- eight control bus signals
- three tag line signals
- one write data signal

3.2.2.1 Control bus signals

The control bus signals, transferred over eight lines, are used to transfer address and control information to the disk drive unit, refer to figure 3.(1).

3.2.2.2 Tag line signals

The significance of the information on the control bus signal lines is indicated by one of three tag line signals, one at a time, refer to figure 3.(1).

3.2.2.3 Difference select signal

When this signal is "0", it is indicated to the disk drive unit that the eight control bus signals contain positioning information, which is the difference between the present cylinder address and the desired cylinder address.

3.2.2.4 Head select signal

When this signal is "0", it is indicated to the disk drive unit, that the eight control bus signals contain information which is the desired head address.

Note: The binary coded difference select and head select information is transferred in an inverted way i.e.
a binary 1 results in a logic "0" and
a binary 0 in a logic "1" on the cable.

status		supers doc.no.	dept. Prod. planning
REV	B		author H.v. Maastricht
		N.V. PHILIPS - ELECTROLOGICA Peripheral Equipment Division	date 70-03-12
			page 3-2

3.2.2.5 Control select signal

When this signal is "0", it is indicated to the disk drive unit that the eight control bus signals contain control commands as follows :

<u>Control bus</u>	<u>Signal</u>	<u>Function</u>
bit 0	WRITE ENABLE	When this signal is "0" it shall enable the write driver.
bit 1	READ ENABLE	When this signal is "0" it shall activate the read amplifier.
bit 2	SEEK FORWARD	When this signal is "0" it shall initiate the head positioning sequence in a forward (towards centre) direction.
bit 3	Not used	
bit 4	ERASE ENABLE	When this signal is "0" it shall activate the erase driver to pass current through the head erase coil.
bit 5	SEEK REVERSE	When this signal is "0" it shall initiate the head positioning sequence in a reverse direction.
bit 6	RETURN TO ZERO	When this signal is "0" it shall initiate the head positioner to move to track 000.
bit 7	Not used	

3.2.2.6 Write data signal

The write data signal line is used to transfer write data to the disk drive unit. In case of write data, the write data signal is defined by figure 3.(2).

All rights strictly reserved. Reproduction in any form or by any means whatsoever is not permitted without written authority from the proprietors.

Property of
Eigendom van:
N.V. PHILIPS - ELECTROLOGICA
Apeldoorn Nederland

Alle rechten uitsluitend voorbehouden.
Afschrijving of mededeling aan
derden of openbaar verspreiden
schriftelijke toestemming van eigenaars
niet geoorloofd.

status		supers doc.no.	dept. Prod. planning
REV.	B		autho H.v.Maastricht
N.V. PHILIPS - ELECTROLOGICA Peripheral Equipment Division			date 70-03-12
			page 3-3

ENGINEERING SPECIFICATION X 1210

doc.no.

reg.no.

CN 070/03005/523

distribution

3.2.3 Output signals

The output signals are the following :

- read data signal
- index signal
- sector signal
- unit unsafe signal
- unit ready signal
- on cylinder signal

3.2.3.1 Read data signal

The read data signal line is used to transfer read data to the control unit. In case of read data, the read data signal is defined by figure 1.4.3.4.

3.2.3.2 Index signal

When this signal is "0" it indicates that the index slot passes the index unit's location.

3.2.3.3 Sector signal

When this signal is "0" it indicates that one of the sector slots passes the sector unit's location.

3.2.3.4 Unit unsafe signal

When this signal is "0" it indicates that the disk drive unit has one or more of the following fault conditions during normal operation:

- 1 - more than one head selected
- 2 - write current without write enable at
- 3 - read enable and write enable or erase enable the same time
- 4 - write data and no alternating write current
- 5 - erase current and no write enable
- 6 - write enable and no erase current
- 7 - write or erase driver enabled and no "On cylinder" signal
- 8 - drive motor stopped or incorrect motor speed
- 9 - the heads shall pass track 000 or 203 during a normal seek operation

The unit unsafe signal will be set within :

- less than 0,5 usec for the fault conditions 8 and 9
- about 50 usec for the fault conditions 1, 2, 3, 4 and 7.
- about 200 usec for the fault conditions 5 and 6

The write and erase heads will be switched off during fault conditions 1 through 7.

The unit unsafe signal will not be set during the start and stop sequence.

All rights strictly reserved. Reproduction or issue to third parties in any form whatever is not permitted without written authority from the proprietors.

Property of
N.V. PHILIPS - ELECTROLOGICA
Nederland
Aperidoorn

Alle rechten uitsluitend voorbehouden.
Vernieuwing of mededeling aan
derden, in welke vorm ook, is zonder
schriftelijke toestemming van eigenaars
niet geoorloofd.

status		supers doc.no.	dept Prod. planning
REV.	B		author H.v. Maastricht
REV.	E ₂	N.V. PHILIPS - ELECTROLOGICA	date 70-07-08
		I.G. Peripheral Equipment	page 3-4

3.2.3.5 Unit ready signal

When this signal is "0", the disk drive unit is available, as follows:

- the cartridge is in position
- the drawer is locked in the rack
- the disk is on speed

3.2.3.6 On cylinder signal

When this signal is "0" it is indicated that the heads are stopped and that the seek operation has been finished.

3.2.4 I/O circuit characteristics

All input and output signals will be digital. Transmission between the disk drive unit and its control unit will be on twisted pair cables for status and control signals.* No line terminators will be required.

The signals on the I/O connector will have the following characteristics:

- the active logic "0" level will be between 0 V and + 0,4 V
- the inactive logic "1" level will be between + 2,4 V and + 5,3 V
- the rise and fall times of the relative fast signals like data, index and sector will be less than (typical value) 10 nsec., measured from 10% to 90% of full steady state level
- the rise and fall times of the relative slow signals like commands and status signals will be less than (typical) 100 nsec., measured from 10% to 90% of full steady state level
- the voltages on connector contact numbers 2, 4, 6, 8, 10 etc. will be positive with respect to the voltages on the contact numbers 1, 3, 5, 7, 9 etc.
- the timing of the interface signals, in co-operation with some internal signals and actions, is given in figures 3.(2) through 3.(12).
- the input and output circuits are given in figure 3.(13) and 3.(14).

*

The read and write data signals will be transferred by coaxial cables.

status		supers doc.no.	dept. Prod.planning
REV.	B		
		N.V. PHILIPS - ELECTROLOGICA Peripheral Equipment Division	date 70-03-12
			page 3-5

3.3 Connectors

3.3.1 A.C. power interface connector

The A.C. power to the disk drive unit will be supplied by means of a cable from a power supply unit. The cable will be attached to the unit by means of a CANNON connector. It is recommended to use shielded twisted pair (for hot and neutral) cable.

Connectors :

receptacle on the unit : MS3102E20-17P
 plug at the cable : MS3106E20-17S(C)(straight type)
 with clamp AN3057-10

Wiring :

wire assignment

contact assignment

220 VAC (hot)	C
spare	B
spare	D
220 VAC (neutral)	E
safety earth	A
spare	F

3.3.2 D.C. power interface connector

The D.C. power to the disk drive unit will be supplied by means of the signal interface connector.

All rights strictly reserved. Reproduction or issue in any form without written authority from the proprietors.

Property of
 Eigendom van:
 N.V. PHILIPS - ELECTROLOGICA
 Apeldoorn
 Nederland

Alle rechten uitdrukkelijk voorbehouden. Vermenigvuldiging of mededeling aan derden, in welke vorm ook, is zonder schriftelijke toestemming van eigenaars niet geoorloofd.

status		supers doc.no.	dept. Prod. planning
REV.	B		author H.v.Maastricht
REV.	D		date 70-03-12
N.V. PHILIPS - ELECTROLOGICA Peripheral Equipment Division			page 3-6

3.3.3. Signal interface connector

The data, control and status signals to and from the disk drive unit are supplied by means of a cable to and from its control unit. The cable will be attached to the unit by means of a Socapex connector. Also the D.C. voltages will be supplied to the unit by means of this 78-pole connector.

Connectors :

receptacle on the unit : EA 67-78AX (without accessory parts)
 plug at the cable : FDA67-78AX (" " ")

Wiring :

<u>Wire assignment</u>	<u>Contact assignment</u>
control bus, bit 4	1 - 2
control bus, bit 5	3 - 4
spare	5 - 6
control bus, bit 6	7 - 8
write data signal	9 - 10
spare	11 - 12
control bus, bit 7	13 - 14
read data signal	15 - 16
spare	17 - 18
tagline control select	19 - 20
reserved	21 - 22
spare	23 - 24
on cylinder	25 - 26
tagline head select	27 - 28
spare	29 - 30
unit ready	31 - 32
tagline difference select	33 - 34
spare	35 - 36
index signal	37 - 38
unit unsafe	39 - 40
logic earth	41
spare	42
sector signal	43 - 44
+ 24 V	45 - 46 ⌘
spare	47 - 48
reserved	49 - 50
+ 24 V	51 - 52 ⌘
spare	53 - 54
control bus, bit 2	55 - 56
+ 24 V	57 - 58 ⌘
spare	59 - 60
control bus, bit 1	61 - 62

⌘ The +24VDC. power is supplied at the same time via three pairs of contacts.

All rights strictly reserved. Reproduction or issue to third parties in any form whatever is not permitted without written authority from the proprietors.

Eigendom van: Property of
 N.V. PHILIPS - ELECTROLOGICA
 Apeldoorn Nederland

Alle rechten uitsluitend voorbehouden. Vermenigvuldiging of mededeling aan derden, in welke vorm ook, is zonder schriftelijke toestemming van eigenaars niet geoorloofd.

status		supers doc.no.	dept Prod.Planning author H.v.Maastricht
REVISION	E		
		N.V. PHILIPS - ELECTROLOGICA I.G. Peripheral Equipment	date 71-06-30
			page 3-7

ENGINEERING SPECIFICATION X 1210

doc.no.

reg.no.
CN 070/03005/523

distribution

3.3.3 (Continued)

+ 5 V	63 - 64 *
spare	65 - 66
control bus, bit 0	67 - 68
+ 5 V	69 - 70 *
spare	71 - 72
control bus, bit 3	73 - 74
- 12 V	75 - 76 **
spare	77 - 78

- * The + 5 V is supplied at the same time via two pairs of contacts.
- ** Contact nr. 76 is negative with respect to nr. 75.

NOTE :

All interface signals are defined here

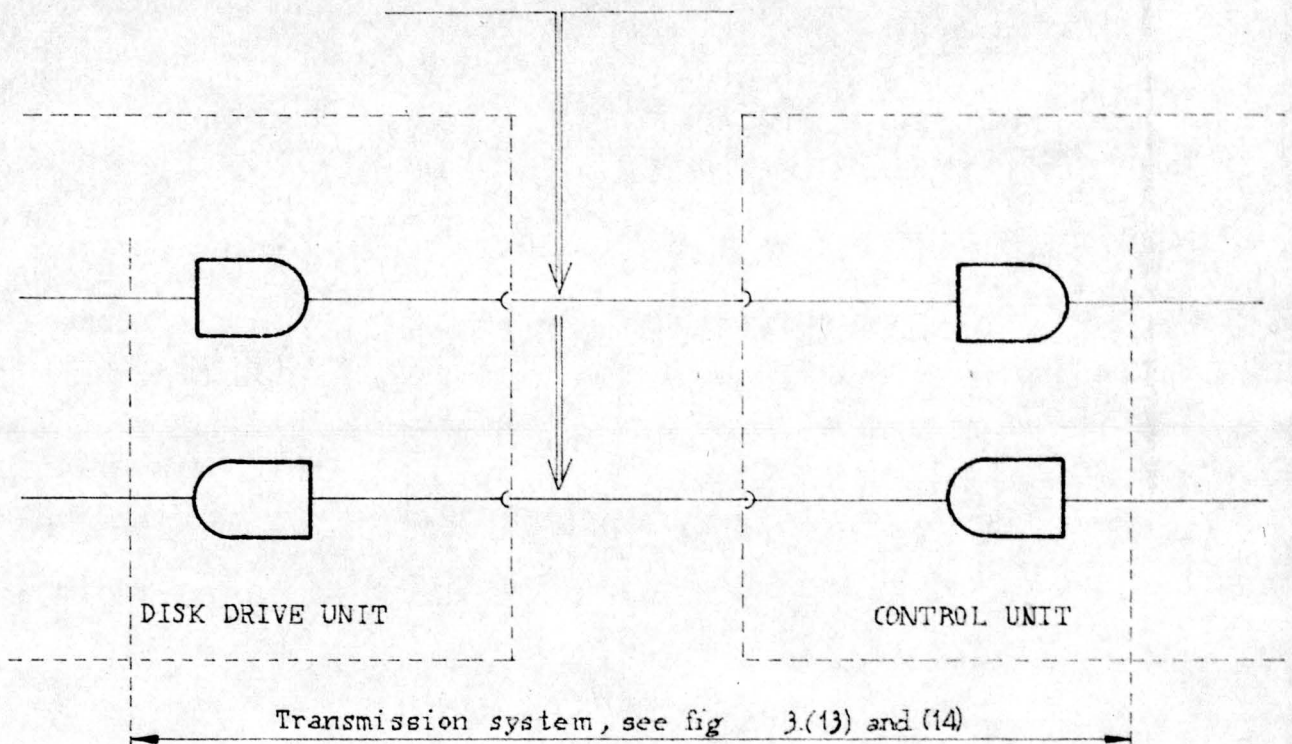

All rights strictly reserved. Reproduction or issue to third parties in any form whatsoever is not permitted without written authority from the Proprietors.

Property of
N.V. PHILIPS - ELECTROLOGICA
Netherlands
Apeldoorn

Alle rechten uitdrukkelijk voorbehouden.
Vernieuwingsrechten of mededeling aan
derden, in welke vorm ook, is zonder
schriftelijke toestemming van eigenaars
niet geoorloofd.

status		supers doc.no.	dept. Prod.planning
REV.	B		author H.v.Maastricht
REV.	F		date 70-03-12
N.V. PHILIPS - ELECTROLOGICA Peripheral Equipment Division			page 3-8

All rights strictly reserved. Reproduction or issue to third parties in any form whatever is not permitted without written authority from the proprietors.

Property of
Eigendom van:
N.V. PHILIPS - ELECTROLOGICA
Apeldoorn
Nederland

Alle rechten uitdrukkelijk voorbehouden.
Vernieuwgeving of mededeling aan
derden, in welke vorm ook, is zonder
schriftelijke toestemming van eigenaars
niet geoorloofd.

TAG LINE FUNCTIONS			
CONTROL BUS	DIFFERENCE SELECT	HEAD * SELECT	CONTROL SELECT
BIT 0	1	1	WRITE ENABLE
BIT 1	2	Not used	READ ENABLE
BIT 2	4	Not used	SEEK FORWARD
BIT 3	8	" "	Not used
BIT 4	16	" "	ERASE ENABLE
BIT 5	32	" "	SEEK REVERSE
BIT 6	64	" "	RETURN TO ZERO
BIT 7	128	" "	Not used

TAG CONTROLLED LINE ORGANIZATION

FIGURE 3.(1)

* Head selection code

Bit 0	Head
1	00
0	01

status		supers doc.no.	dept. Prod. planning
REV	B		author H.v.Maastricht
N.V. PHILIPS - ELECTROLOGICA Peripheral Equipment Division			date 70-03-12
			page 3-9

All rights strictly reserved. Reproduction in any form without written permission is not permitted without written authority from the proprietors.

Bit value

Write data signal

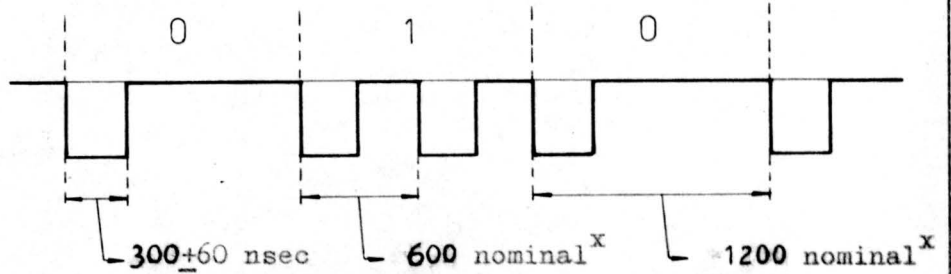

- ^x - long term stability $\pm 0,3\%$
- pulse to pulse variation $\pm 1,0\%$

WRITE DATA TIMING

FIGURE 3.(2)

Bit value

Read data signal

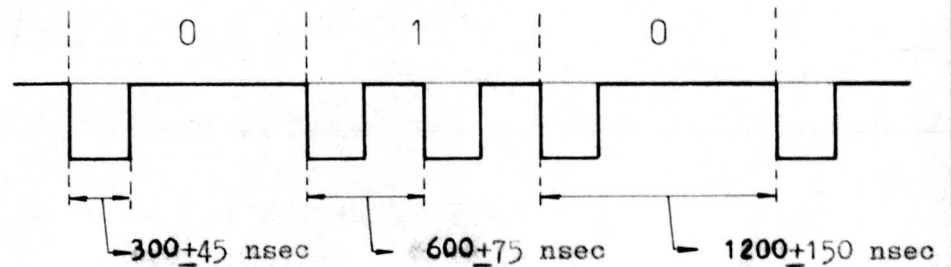

READ DATA TIMING

FIGURE 3.(3)

Property of
Eigendom van:
N.V. PHILIPS - ELECTROLOGICA
Apeldoorn
Nederland

Alle rechten uitdrukkelijk voorbehouden.
Vernieuwing of mededeling aan
derden, in welke vorm ook, is zonder
schriftelijke toestemming van eigenares
niet geoorloofd.

status		supers.doc.no.	dept. Prod.planning
REV	B		
N.V. PHILIPS - ELECTROLOGICA Peripheral Equipment Division			date 70-03-12
			page 3-10

ENGINEERING SPECIFICATION X 1210

doc.no.

reg.no.

CN 070/03005/523

distribution

All rights strictly reserved. Reproduction or issue to third parties in any form whatever is not permitted without written authority from the proprietors.

Property of
N.V. PHILIPS - ELECTROLOGICA
Nederland
Apeldoorn

Alle rechten uitdrukkelijk voorbehouden.
Vermenigvuldiging of mededeling aan
derden, in welke vorm ook is zonder
schriftelijke toestemming van eigenaar
niet geoorloofd.

A.C. voltage present

D.C. voltages present

Retrack unless retracted

Start-stop push button actuated

Drive motor power

Sufficient speed

Cleaning cycle

Head loading cycle

Unit ready signal

On cylinder signal

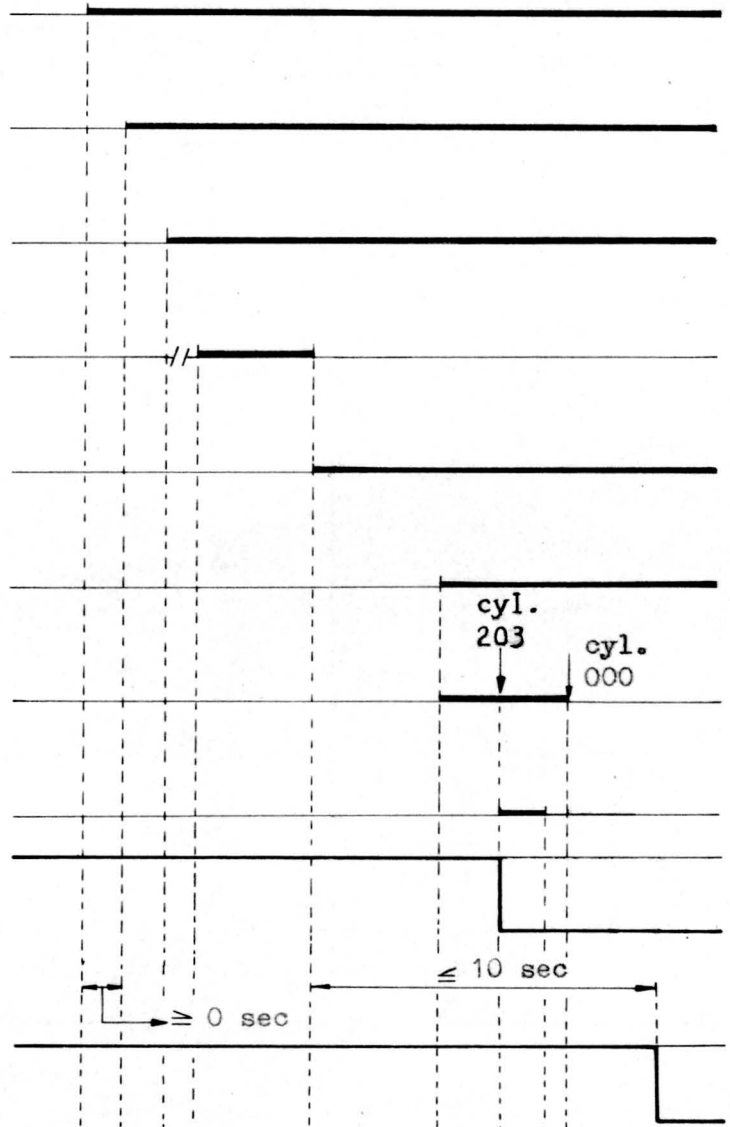

TURN ON TIMING

FIGURE 3.(4)

status		supers doc.no.	dept. Prod.planning
REV	B		author H.v.Maastricht
N.V. PHILIPS - ELECTROLOGICA Peripheral Equipment Division			date 70-03-12
			page 3-11

ENGINEERING SPECIFICATION X 1210

doc.no.

reg.no.
CN 070/03005/523

distribution

All rights strictly reserved. Reproduction or issue to third parties in any form whatever is not permitted without written authority from the proprietors.

Eigendom van: Property of
N.V. PHILIPS - ELECTROLOGICA
Apeldoorn Nederland

Alle rechten uitdrukkelijk voorbehouden. Verspreiding of mededeling aan derden, in welke vorm ook, zonder schriftelijke toestemming van eigenares niet geoorloofd.

Start-stop push button actuated

Heads unloaded

Retracting cycle

Drive motor power

Braking

Unit ready signal

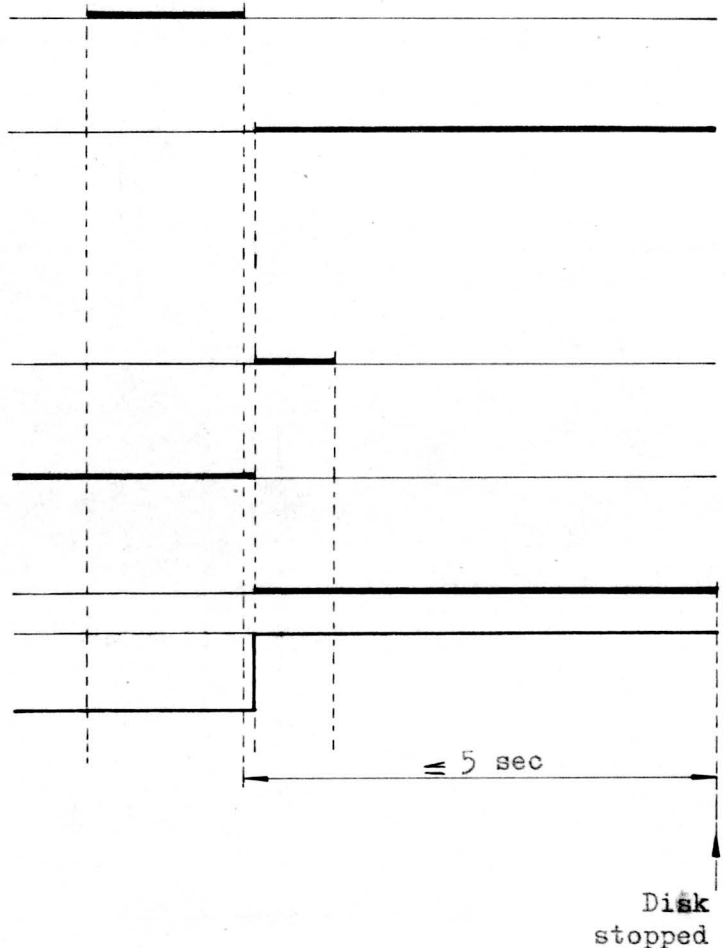

TURN OFF TIMING

FIGURE 3.(5)

status		supers doc.no.	dept. Prod.planning
REV.	B		
		N.V. PHILIPS - ELECTROLOGICA Peripheral Equipment Division	date 70-03-12
			page 3-12

ENGINEERING SPECIFICATION X 1210

doc.no.

reg.no.

CN 070/03005/523

distribution

All rights strictly reserved. Reproduction or issue to third parties in any form whatever is not permitted without written authority from the proprietors.

Eigendom van: Property of
N.V. PHILIPS - ELECTROLOGICA
Apeldoorn Nederland

Alle rechten uitdrukkelijk voorbehouden. Vermenging, uitlegging of mededeling aan derden, in welke vorm ook, is zonder schriftelijke toestemming van eigenares niet geoorloofd.

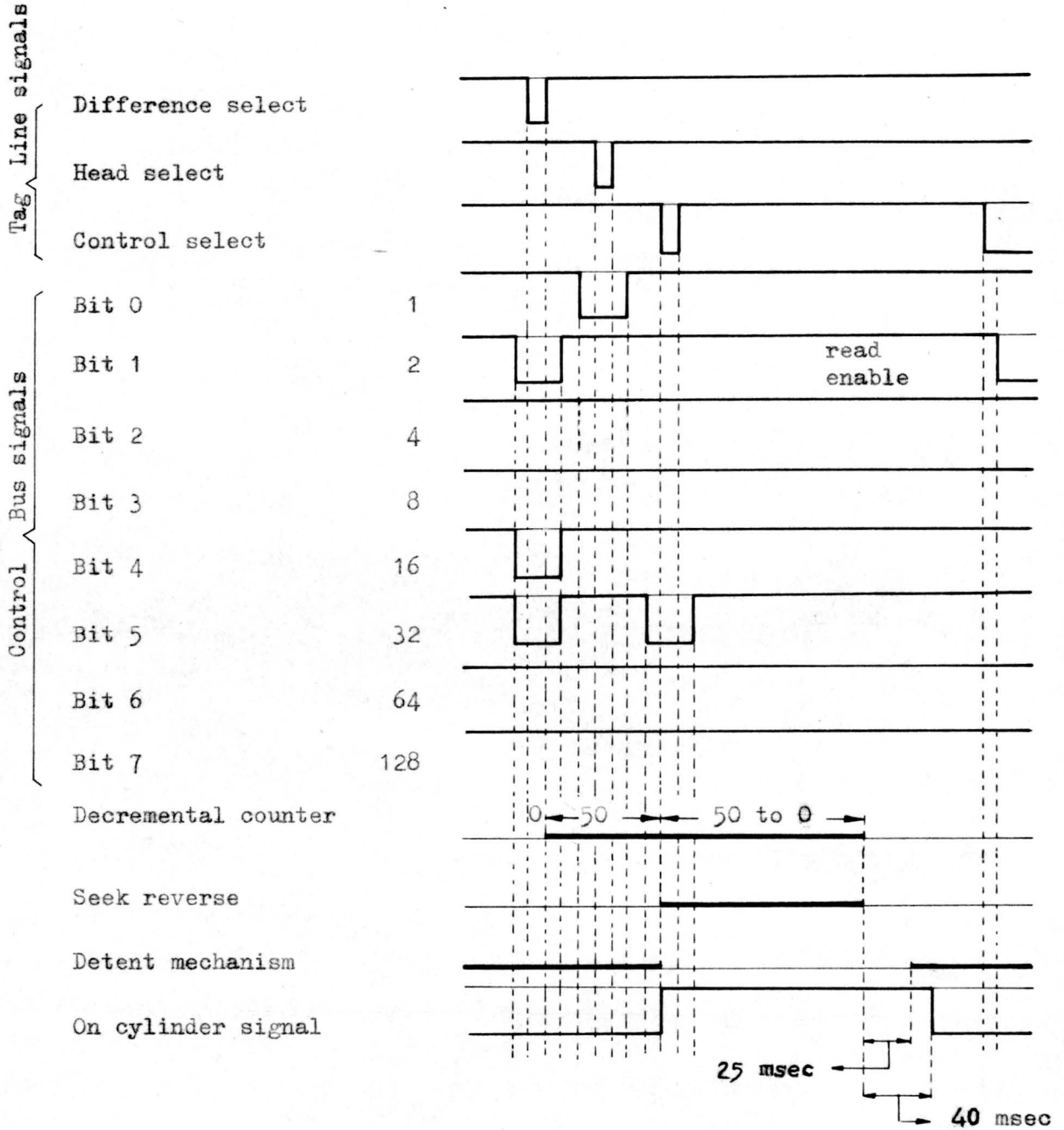

DIRECT SEEK TIMING

(example cyl. 60 reverse to cyl. 10)

FIGURE 3.(6)

status		supers doc.no.	dept. Prod.planning
REV.	B		
N.V. PHILIPS - ELECTROLOGICA Peripheral Equipment Division			date 70-03-12
			page 3-13

ENGINEERING SPECIFICATION X 1210

doc.no.
 reg.no.
 CN 070/03005/523
 distribution

All rights strictly reserved. Reproduction or issue to third parties in any form whatever is not permitted without written authority from the proprietors.

Eigendom van: Property of
 N.V. PHILIPS - ELECTROLOGICA
 Apeldoorn Nederland

Alle rechten uitdrukkelijk voorbehouden. Vermengvuldiging of mededeling aan derden in welke vorm ook, is zonder schriftelijke toestemming van eigenaars niet geoorloofd.

Control bus: Bit 6

Tagline : Control select

Return to zero

Detent mechanism

On cylinder signal

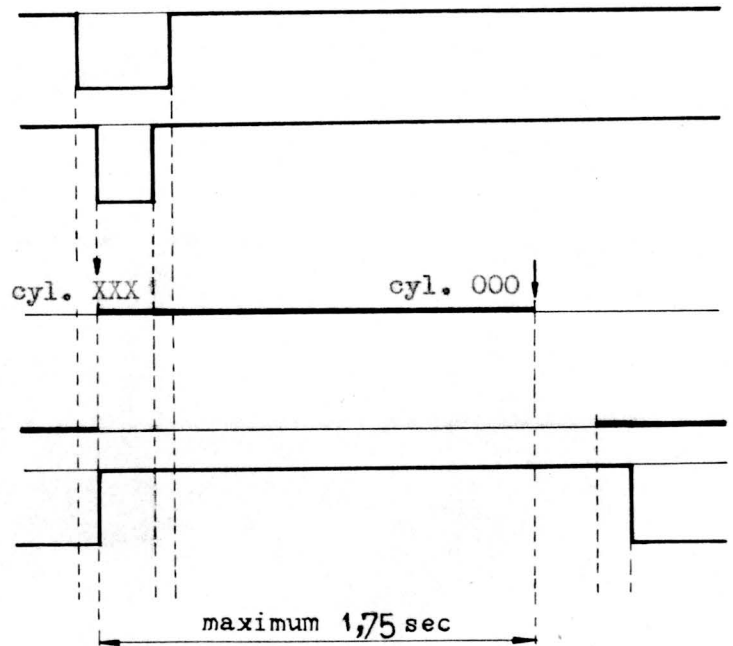

RETURN TO ZERO SEEK TIMING

FIGURE 3.(7)

status		supers doc.no.	dept. Prod.planning
REV.	B		
REV.	E	N.V. PHILIPS - ELECTROLOGICA Peripheral Equipment Division	date 70-03-12
			page 3-14

ENGINEERING SPECIFICATION X 1210

doc.no.

reg.no.
CN 070/03005/523

distribution

All rights strictly reserved. Reproduction or issue to third parties in any form whatever is not permitted without written authority from the proprietors.

Eigendom van: Property of
N.V. PHILIPS - ELECTROLOGICA
Apeldoorn Nederland

Tagline signal

Tagline signal

Control bus: Bits 0 through 7

minimum 0,5 μ sec.

maximum 10,0 μ sec

minimum 1,0 μ sec

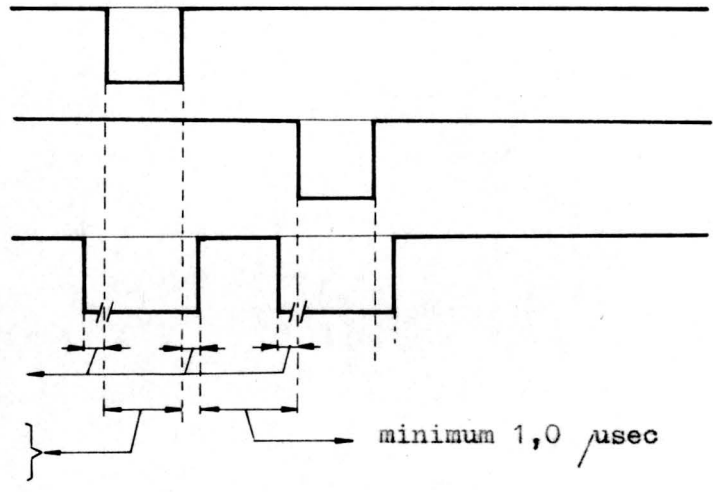

DIFFERENCE SELECT, HEAD SELECT, CONTROL
SELECT (SEEK FORWARD, SEEK REVERSE,
RETURN TO ZERO) TAGLINE TIMING

FIGURE 3.(8)

Alle rechten uitdrukkelijk voorbehouden.
Vermenigvuldiging of mededeling aan
derden, in welke vorm ook, is zonder
schriftelijke toestemming van eigenares
niet geoorloofd.

status		supers doc.no.	dept. Prod.planning
REV.	B		author H.v.Maastricht
N.V. PHILIPS - ELECTROLOGICA Peripheral Equipment Division			date 70-03-12
			page 3-15

All rights strictly reserved. Reproduction or issue to third parties in any form whatever is not permitted without written authority from the proprietors.

Eigendom van: N.V. PHILIPS - ELECTROLOGICA Apeldoorn
Property of: N.V. PHILIPS - ELECTROLOGICA Nederland

Alle rechten uitdrukkelijk voorbehouden. Vermenigvuldiging of mededeling aan derden, in welke vorm ook, is zonder schriftelijke toestemming van eigenaars niet geoorloofd.

Tagline: Control select

Tagline: Head select

Index or sector signal

Head selected

Control bus: Read enable

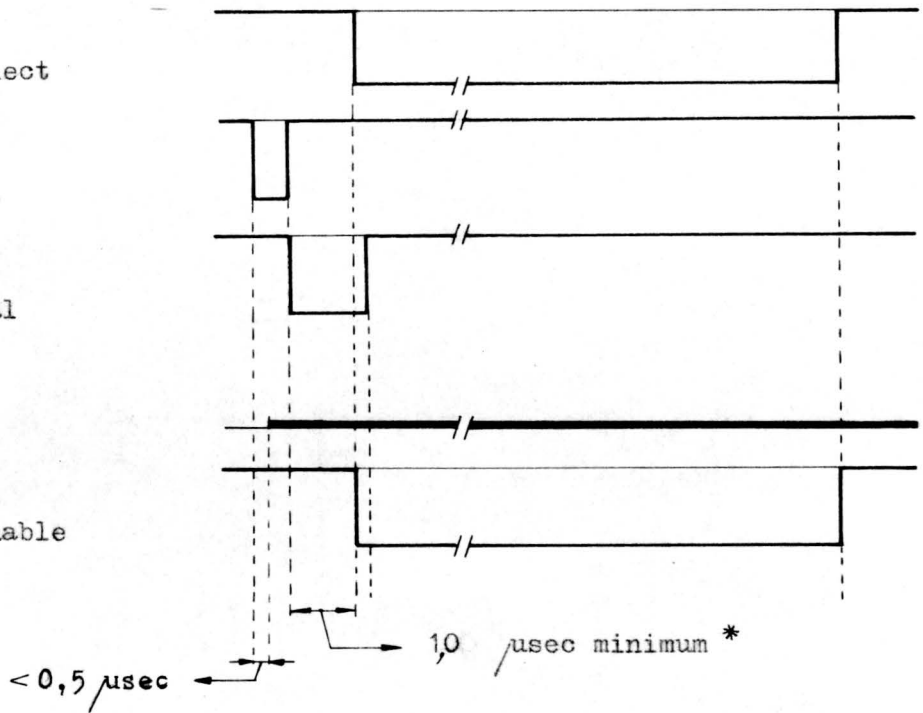

Note: Head select shown in latest acceptable position with reference to index or sector; not to be considered a typical relationship.

READ CONTROL TIMING

FIGURE 3.(9)

* Correct data can be read however only after 10 μsec.

status		supers doc.no.	dept. Prod. planning
REV.	B		author H.v.Maastricht
N.V. PHILIPS - ELECTROLOGICA Peripheral Equipment Division			date 70-03-12
			page 3-16

All rights strictly reserved. Reproduction or issue to third parties in any form whatever is not permitted without written authority from the proprietors.

Eigendom van:
N.V. PHILIPS - ELECTROLOGICA
Apeldoorn
Nederland

Alle rechten uitdrukkelijk voorbehouden. Vermenigvuldiging of mededeling aan derden, in welke vorm ook, is zonder schriftelijke toestemming van eigenares niet geoorloofd.

Tagline : Control select

Control bus: Write enable

Control bus: Erase enable

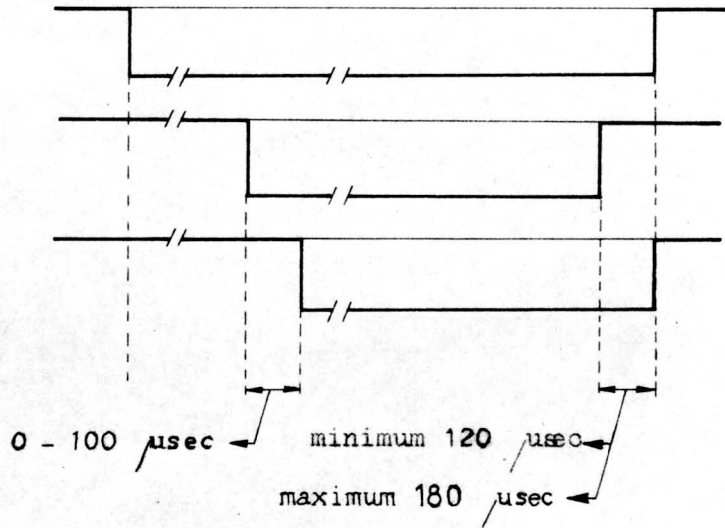

WRITE CONTROL TIMING

FIGURE 3.(10)a

status		supers doc.no.	dept Prod.planning
REV.	B		author H.v.Maastricht
REV.	E1	N.V. PHILIPS - ELECTROLOGICA I.G. Peripheral Equipment	date 70-03-12
REV.	F		page 3-17a

All rights strictly reserved. Reproduction or issue to third parties in any form whatever is not permitted without written authority from the proprietors.

Eigendom van: Property of
 N.V. PHILIPS - ELECTROLOGICA
 Apeldoorn Nederland

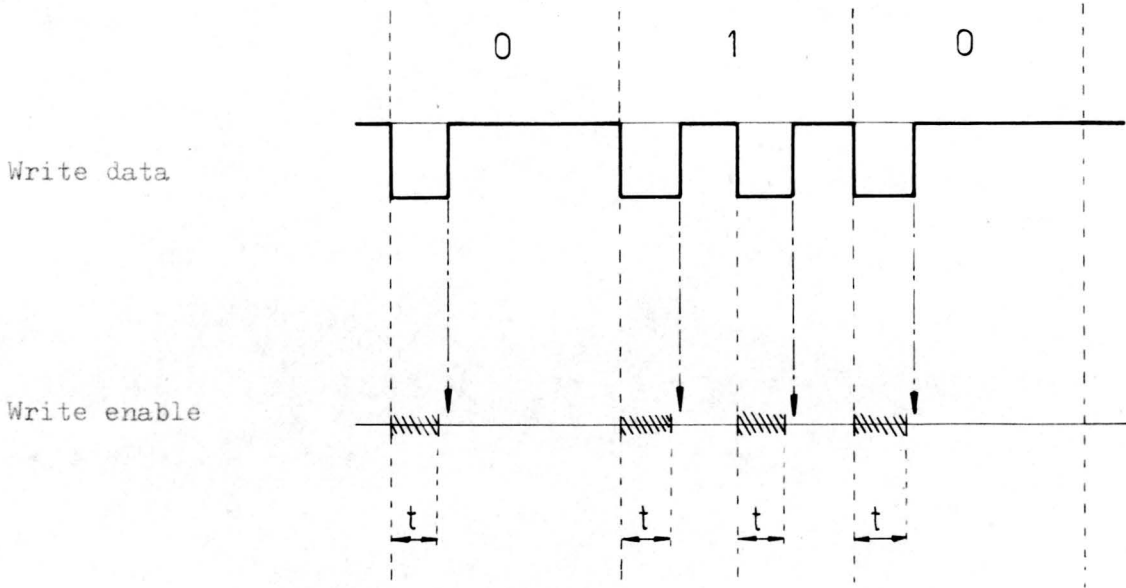

TIMING RELATION WRITE DATA-WRITE ENABLE
AT THE END OF A WRITE OPERATION

▨ = forbidden area; in which it is not allowed to switch off Write Enable, during a write operation.

t = 200 nsec.

↓ = recommended moments, to switch off Write Enable in order to stop the Write operation.

FIGURE 3.(10)b

Alle rechten uitdrukkelijk voorbehouden. Vermenigvuldiging of mededeling aan derden, in welke vorm ook, is zonder schriftelijke toestemming van eigenares niet geoorloofd.

status		supers doc.no.	dept. ProductPlanning
REV.	F		author H.v.Maastricht
N.V. PHILIPS - ELECTROLOGICA I.G. Peripheral Equipment			date 71-08-05
			page 3-17b

All rights strictly reserved. Reproduction or issue to third parties in any form whatever is not permitted without written authority from the proprietors.

Eigendom van: N.V. PHILIPS - ELECTROLOGICA, Apeldoorn, Nederland

Alle rechten uitdrukkelijk voorbehouden. Vermenigvuldiging of mededeling aan derden, in welke vorm ook, is zonder schriftelijke toestemming van eigenares niet geoorloofd.

Tagline : Control select

Control bus: Read enable

Control bus: Write enable

Control bus: Erase enable

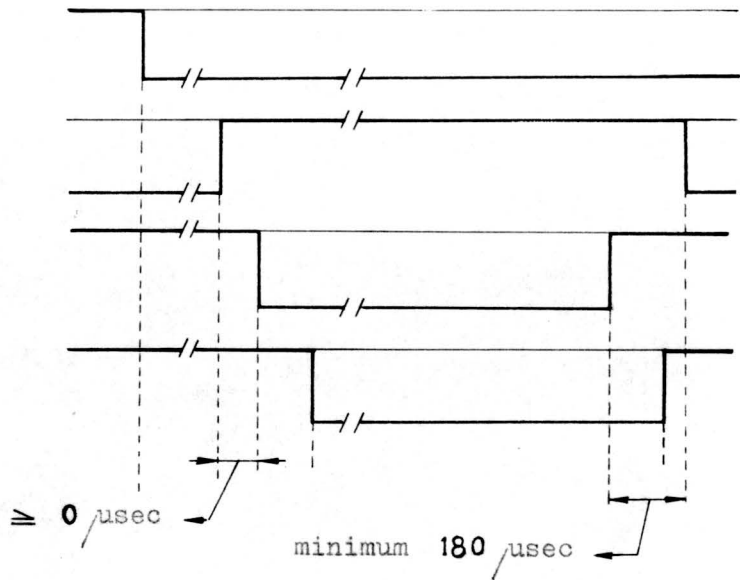

READ/WRITE CONTROL TIMING

FIGURE 3.(11)

status		supers doc.no.	dept. Prod.planning
REV.	E		author H.v.Maastricht
REV	F	N.V. PHILIPS - ELECTROLOGICA	date 70-03-12
		I.G. Peripheral Equipment	page 3-18

All rights strictly reserved. Reproduction or issue to third parties in any form whatever is not permitted without written authority from the proprietors.

Eigendom van: Property of
N.V. PHILIPS - ELECTROLOGICA
Apeldoorn Nederland

Alle rechten uitdrukkelijk voorbehouden. Vermenigvuldiging of mededeling aan derden, in welke vorm ook, is zonder schriftelijke toestemming van eigenares niet geoorloofd.

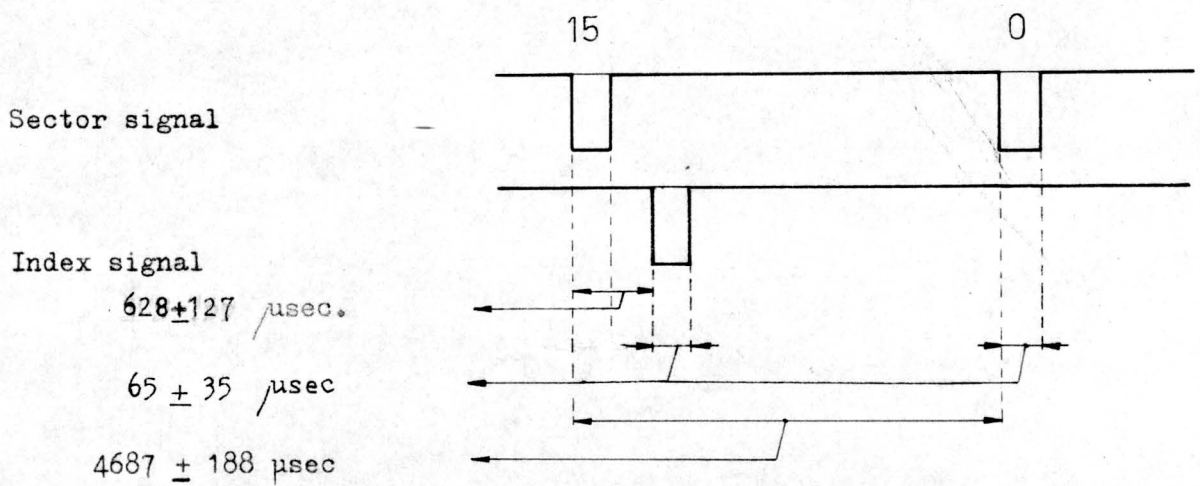

A. timing with 16 sectors

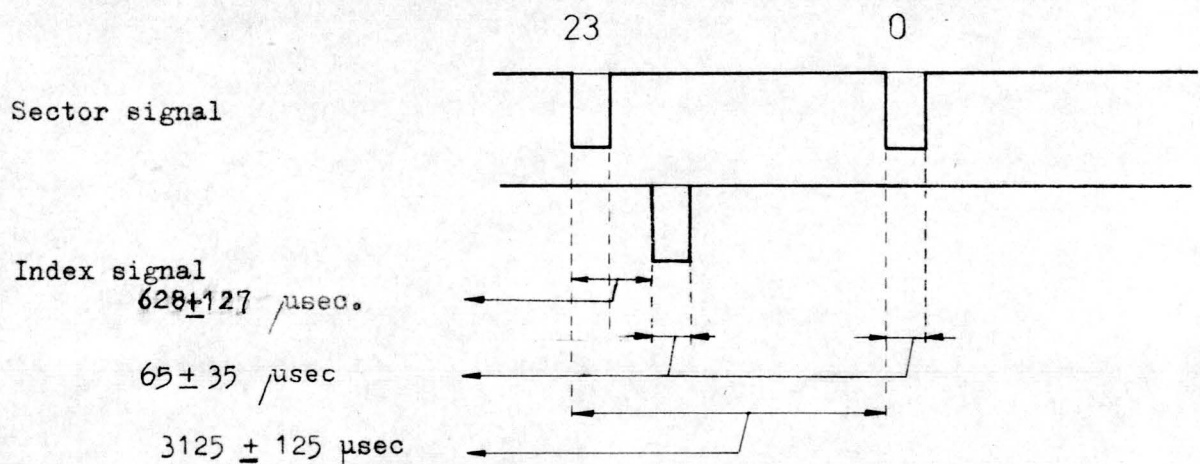

B. timing with 24 sectors

INDEX AND SECTOR TIMING

FIGURE 3.(12)

status		supers doc.no.	dept Prod.planning
REV.	B		author H.v.Maastricht
N.V. PHILIPS - ELECTROLOGICA I.G. Peripheral Equipment			date 70-04-08
			page 3-19

ENGINEERING SPECIFICATION X 1210

doc. no.
 reg. no. CN 970/03005/523
 distribution

All rights strictly reserved. Reproduction or issue to third parties in any form whatsoever is not permitted without written authority from the proprietor.

Property of
 N.V. PHILIPS - ELECTROLOGICA
 Apeldoorn Nederland

Alle rechten uitsluitend voorbehouden. Verspreiding of mededeling van de inhoud schriftelijke toestemming van eigenaars niet geoorloofd.

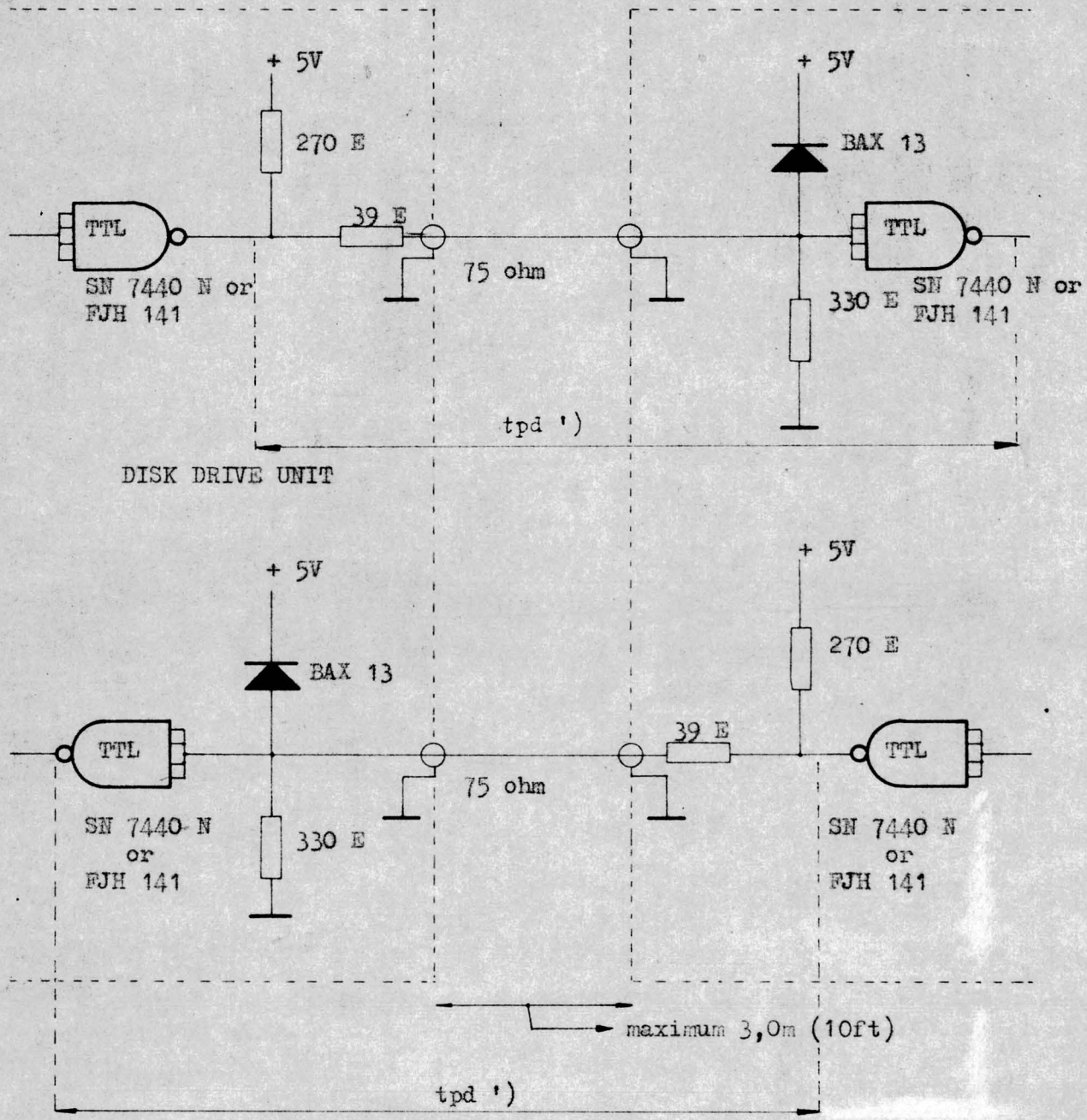

INPUT AND OUTPUT CIRCUITS FOR READ AND WRITE DATA

Figure 3.(13)

') tpd	typical	maximum
tpd _{rise}	35 nsec	55 nsec
tpd _{fall}	30 nsec	45 nsec

status		supers doc no.	dept Prod. planning
REV.	B		author H.v.Maastricht
N.V. PHILIPS - ELECTROLOGICA I.G. Peripheral Equipment			date 70-07-08
			page 3-20

All rights strictly reserved. Reproduction or issue to third parties in any form whatever is not permitted without written authority from the proprietors.

Property of
N.V. PHILIPS - ELECTROLOGICA
Apeldoorn Nederland

Alle rechten uitdrukkelijk voorbehouden.
Vernieuwing of mededeling aan
derden, in welke vorm ook, is zonder
schriftelijk toestemming van eigenares
niet geoorloofd.

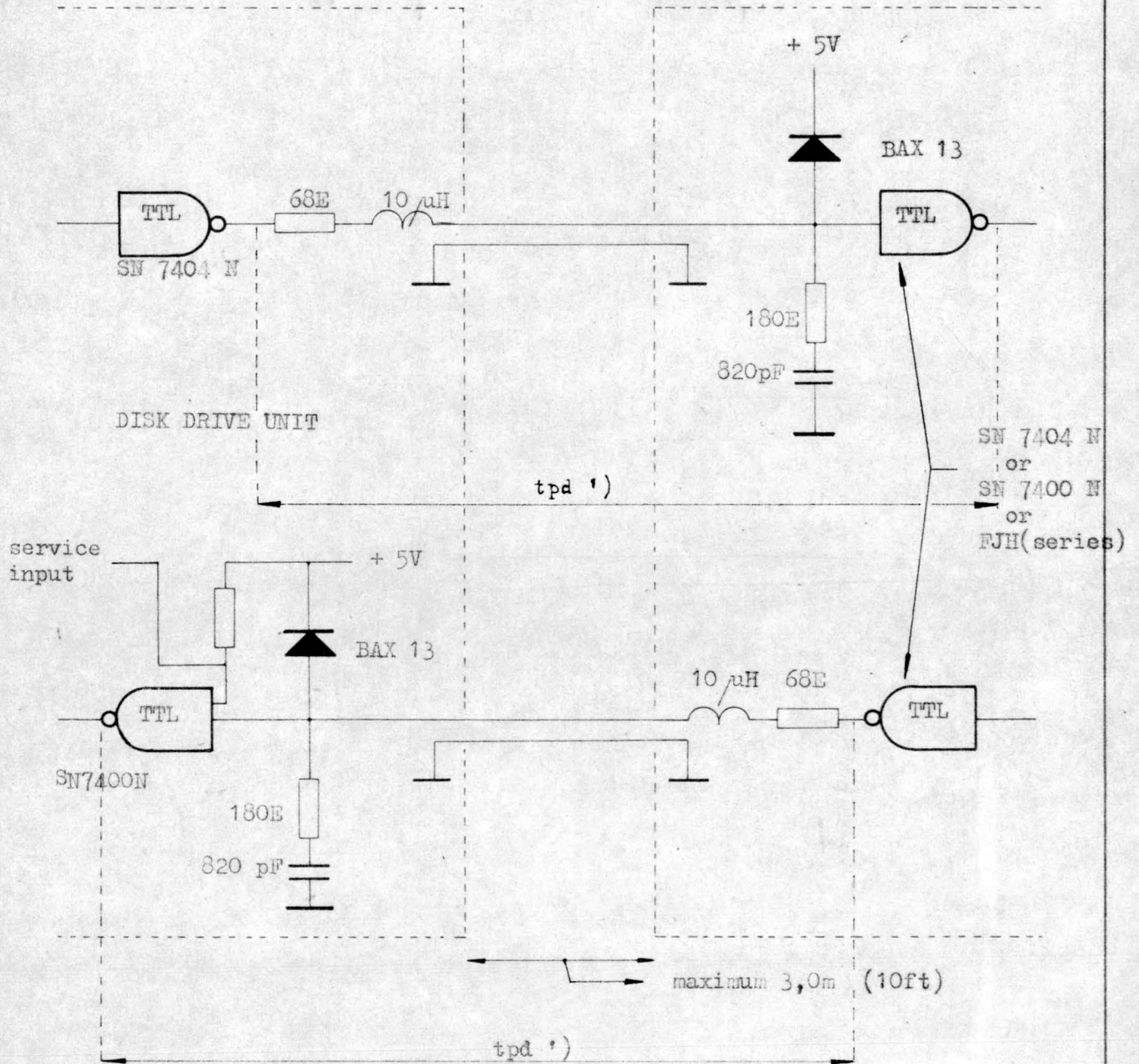

INPUT AND OUTPUT CIRCUITS FOR BUS, TAG

AND STATUS SIGNALS

1) tpd	typical	maximum
tpd _{rise}	120 nsec	150 nsec
tpd _{fall}	90 nsec	120 nsec

Figure 3.(14)

status	supers doc no.	dept	Prod. planning
REV.	B	author	H.v. Maastricht
		date	70-07-08
		page	3-21

N.V. PHILIPS - ELECTROLOGICA
I.G. Peripheral Equipment

doc.no.
reg.no. GN 070/03005/523
distribution

All rights strictly reserved. Reproduction in any form without prior written authority from the proprietors.

Property of
Eigendom van:
N.V. PHILIPS - ELECTROLOGICA
Apeldoorn
Nederland

Alle rechten uitsluitend voorbehouden.
Vernieuwing van de afbeelding aan
derden, in welke vorm ook, is
schriftelijke toestemming van eigenaars
niet geoorloofd.

4 OPERATION

4.1 General

Operation of the disk drive unit is possible by non-trained personnel. The operator controls on the front panel will be failsafe. Safety interlocks are present to protect persons and equipment against damage. The mechanical and electronic parts will be not accessible to the operator. The indicators and switches, shown in figure 4.(1) has been installed.

4.2 Start/stop button/indicator

The START/STOP push button/indicator assembly consists of a springloaded push-to-set, push-to-reset switch, and an indicator START (green).

When the START/STOP push button is depressed :

- either the internal turn-on sequence will be started, provided the cartridge is installed, the mechanism drawer is closed and the * indicator was lighted.
- or the internal turn-off sequence will be started, the heads will unload and move to the retracted position, the disk drive motor will be stopped, when the START indicator was lighted.

The START indicator will be lighted when the preceding turn-on conditions are fulfilled.

The START indicator will:

- light when the START/STOP push button is depressed and the * indicator was lighted
- extinguish when the START/STOP push button is depressed and the START indicator was lighted

4.3 Cartridge exchange indicator

The CARTRIDGE EXCHANGE indicator (green) will be lighted when the operator may replace the cartridge.

The CARTRIDGE EXCHANGE indicator will:

- light when it is safe to replace the cartridge
- extinguish when it is not safe to replace the cartridge

* cartridge exchange.

status		supers doc.no.	dept. Prod. planning
REV.	B		author H.v.Maastricht
N.V. PHILIPS - ELECTROLOGICA Peripheral Equipment Division			date 70-03-12
			page 4-1

4.4 Fault indicator

The FAULT indicator (red) will be lighted when the UNIT UNSAFE signal is present (see para. 3.2.3.4).

The FAULT indicator will:

- light when an Unit Unsafe signal is present
- extinguish when the START/STOP push button is depressed twice, to recycle the start/stop sequence, to indicate that the FAULT condition was only temporarily.

4.5 Start and stop times

When starting the disk drive unit, the time between release of the START/STOP push button and the UNIT READY signal will be less than 10 seconds.

When stopping the disk drive unit, the time between pressing the push button and stand still of the disk will be less than 5 seconds.

All rights strictly reserved. Reproduction or issue to third parties in any form whatever is not permitted without written authority from the proprietors.

Eigendom van: Property of
N.V. PHILIPS - ELECTROLOGICA
Apeldoorn Nederland

Alle rechten uitdrukkelijk voorbehouden.
Vernieuwing of mededeling aan
derden, in welke vorm ook, is zonder
schriftelijke toestemming van eigenares
niet geoorloofd.

status		supers doc.no.	dept. Prod. planning
REV.	B		author H.v. Maastricht
N.V. PHILIPS - ELECTROLOGICA Peripheral Equipment Division			date 70-03-12
			page 4-2

ENGINEERING SPECIFICATION X 1210

doc.no.

reg.no.
CN 070/03005/523

distribution

All rights strictly reserved. Reproduction or issue in any form or by any means is not permitted without written authority from the proprietors.

Eigendom van: Property of
N.V. PHILIPS - ELECTROLOGICA
Apeldoorn Nederland

Alle rechten uitdrukkelijk voorbehouden. Vermenigvuldiging of mededeling aan welke vorm ook, is zonder schriftelijke toestemming van eigenaars niet geoorloofd.

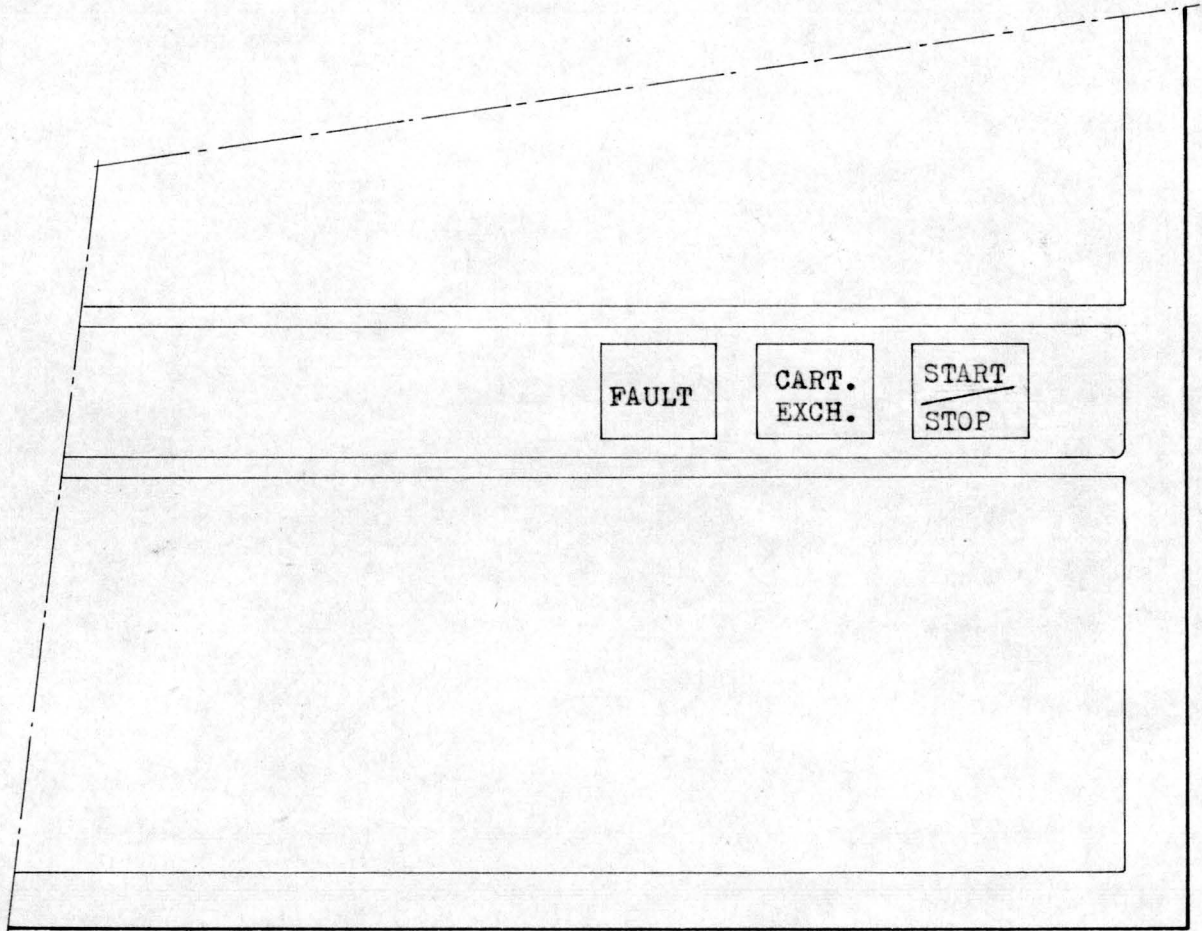

LAY-OUT OPERATOR'S CONTROL PANEL

FIGURE 4.(1)

status		supers doc.no.	dept. Prod. planning author H.v.Maastricht
REV.	B		
		N.V. PHILIPS - ELECTROLOGICA Peripheral Equipment Division	date 70-03-12
			page 4-3

5 TECHNICAL CHARACTERISTICS5.1 Physical description5.1.1 General

The disk drive unit can be installed as a drawer, in a standard 19 inch RETMA rack. When the drawer has been pulled out of the rack, it shall be possible to replace the cartridge (loading position see figure 5.(1).)

5.1.2 Dimensions

The approximate physical dimensions are as follows:

- width :	19 inch	480 mm
- height:	6 units (of rack height)	262 mm
- depth :	inside rack	725 mm (± 0,5 mm)
	front of rack	50 mm

5.1.3 Weight

The weight of the disk drive unit is approximately 45 kg.

5.1.4 Service clearance

Full accessibility for service is provided from the front of the rack when the disk drive unit is pulled out of the rack (maintenance position see figure 5.(2).)

5.1.5 Levelling

The disk drive will operate at the rated performance, when levelled within $\pm 3^{\circ}$ to the horizontal plane.

5.1.6 Unit handling

It shall be possible to lay down the unit for transport and maintenance purposes on each of the sides, except topside, (longitudinal axis) without causing damage (top and bottom covers removed), when the unit is out of the rack.

5.1.7 Cooling

The disk drive unit has a cooling air intake in the front panel. The air will be exhausted through openings in the left and right side covers.

status		supers doc.no.	dept Prod. planning
REV.	B		author H.v. Maastricht
REV.	E ₂	N.V. PHILIPS - ELECTROLOGICA I.G. Peripheral Equipment	date 70-03-12
			page 5-1

ENGINEERING SPECIFICATION X 1210

doc.no.

reg.no.
CN 070/03005/523

distribution

5.2 Environmental conditions

5.2.1 General

The disk drive unit will withstand the following environmental conditions, without damage or down graded performance.

5.2.2 Climatic conditions

- Environmental temperature
 - Operating : + 10 to + 32°C
 - Nonoperating : - 15 to + 65°C
- Thermal shock
 - Operating : maximum 6°C per hour
 - Nonoperating : maximum 17,5°C per hour
- Temperature acclimatisation

Before the equipment is turned on, the equipment shall be in an area with a temperature within the operating environmental range for at least two hours.
- Humidity
 - Relative humidity, providing there is no condensation
 - Operating : 20 to 80%
 - Nonoperating : 5 to 85%
- Heat radiation

Direct sunlight radiation on the disk drive unit is not allowed. This requirement does not apply when the unit is installed in a closed 19 inch rack.
- Moisture

Water exposure is not allowed.
- Dust and sand

The installation area of the disk drive unit will be free of sand and dust, as usual in office rooms.
- Air pressure
 - Operating : from mean sea level to 8000 feet above mean sea level.
 - Nonoperating : from about 750 feet below to 18.000 feet above mean sea level.

All rights strictly reserved. Reproduction or issue to third parties in any form whatsoever is not permitted without written authority from the proprietors.

Property of
Eigendom van:
N.V. PHILIPS - ELECTROLOGICA
Nederland
Apeldoorn

Alle rechten uitsluitend voorbehouden.
Vernieuwingsrechten of mededeling aan
derden in welke vorm ook, is zonder
schriftelijke toestemming van eigenaars
niet geoorloofd.

status		supers doc.no.	dept. Prod. planning
REV.	B		
		N.V. PHILIPS - ELECTROLOGICA Peripheral Equipment Division	date 70-03-12
			page 5-2

5.2.3 Mechanical conditions

- Vibration

Operating : no vibration of any importance is allowed

Nonoperating : a peak displacement of $\pm 0,13$ mm for the frequency range from 5 to 60 Hz and ± 2 g's for the range from 60 to 500 Hz

- Shock

Operating : no shocks of any importance are allowed

Nonoperating : 18 impact shocks of 5 g, $\pm 10\%$ consisting of three shocks in opposite directions along each of three mutually perpendicular axes. Each shock impulse shall have a time duration of 11, ± 1 msec.

- Acceleration

Operating : no acceleration of any importance is allowed

Nonoperating : see para. Vibration and Shock.

5.2.4 Shipping and storage

- Shipping

The equipment itself shall not be subject to conditions worse than specified under 1.4.5.2.2 and 1.4.5.2.3.

Vibration : the packed unit will withstand a peak displacement of 20 mm at a frequency of 5 vibrations per sec. and an acceleration of 1 g on the vertical axis, during one hour

Shock : the packed unit will withstand the following test, performed on the four sides of the unit. The packed unit is fastened to a carriage, which rolls off a slope with a gradient of 10° over a distance of 1,5 m, against a stone wall.

Storage

All rights strictly reserved. Reproduction or issue to third parties in any form whatever is not permitted without written authority from the proprietor.

Eigendom van: Property of
N.V. PHILIPS - ELECTROLOGICA
Apeldoorn Nederland

Alle rechten uitdrukkelijk voorbehouden. Vermenigvuldiging of mededeling aan derden, in welke vorm ook, is zonder schriftelijke toestemming van eigenares niet geoorloofd.

status		supers doc.no.	dept. Prod. planning
REV.	B		
		N.V. PHILIPS - ELECTROLOGICA Peripheral Equipment Division	date 70-03-12
			page 5-3

5.2.4 (continued)

Storage

The equipment itself shall not be subject to conditions worse than specified in 5.2.2 and 5.2.3.

When the unit has been stored for a time longer than 6 months, a technical inspection, as described in the concerning maintenance manual should be performed before the unit is put into operation.

5.3 Mechanical description

All components of the disk drive unit are mounted on the base plate, as follows:

- operator panel
- disk cartridge receptacle
- positioner unit (stepping motor, carriage, head/arm assembly and cleaning mechanism)
- disk drive motor unit (motor, belt and spindle)
- index and sector unit
- electronics (read/write, logic and motor drivers)
- pneumatic unit
- blowers
- top cover
- bottom cover

5.4 Electrical description5.4.1 General

The disk drive unit contains only the electronics and logic necessary for reading, writing, control and diagnostic purposes.

5.4.2 Electrical power

The disk drive unit shall not contain a power supply unit. All voltages required shall be supplied by an external power supply.

5.4.3 Grounding

All metal cabinet parts are connected to safety earth, except those which cannot be touched by the operator may be connected to logic earth. For the logic and other electronics, the logic earth has been used as a reference point and not as return path for D.C. voltages.

status

REV B

supers.doc.no.

dept. Prod.planning

autho H.v.Maastricht

N.V. PHILIPS - ELECTROLOGICA
I.G. Peripheral Equipment

date 70-03-12

page 5-4

ENGINEERING SPECIFICATION X 1210

doc.no.

reg.no.
CN 070/03005/523

distribution

5.4.4 Electronic parts

The logic is being built with standard TTL integrated circuits.

5.5 Maintenance

Scheduled routine preventive maintenance can be performed by suitably trained and competent customer personnel.

The disk drive unit is easy to service when the drawer has been slid out of the rack.

All rights strictly reserved. Reproduction or issue to third parties in any form whatever is not permitted without written authority from the proprietors.

Eigendom van: Property of
N.V. PHILIPS - ELECTROLOGICA
Apeldoorn Nederland

Alle rechten uitdrukkelijk voorbehouden. Vermenigvuldiging of mededeling aan derden, in welke vorm ook, is zonder schriftelijke toestemming van eigenares niet geoorloofd.

status		supers.doc.no.	dept. Prod.planning
REV.	B		author H.v.Maastricht
		N.V. PHILIPS - ELECTROLOGICA	
		I.G. Peripheral Equipment	
			date 70-03-12
			page 5-5

ENGINEERING SPECIFICATION X 1210

doc.no.

reg.no.

CN 070/03005/523

distribution

All rights strictly reserved. Reproduction or issue to third parties in any form whatever is not permitted without written authority from the proprietors.

Eigendom van: Property of
N.V. PHILIPS - ELECTROLOGICA
Apeldoorn Nederland

Alle rechten uitsluitend voorbehouden. Vermenigvuldiging of mededeling aan derden, in welke vorm ook, is zonder schriftelijke toestemming van eigenares niet geoorloofd.

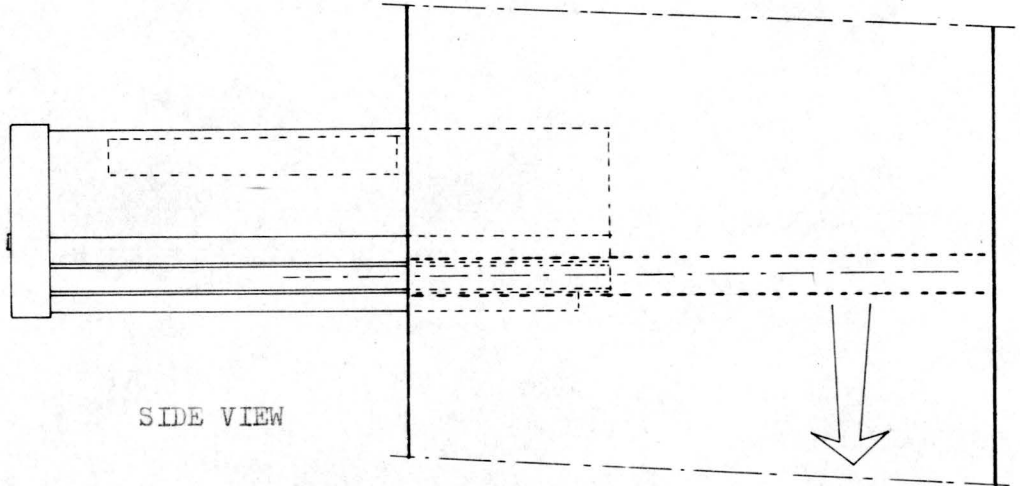

SIDE VIEW

direction of
required balance
force

X 1210 IN CARTRIDGE LOADING POSITION

FIGURE 5.(1)

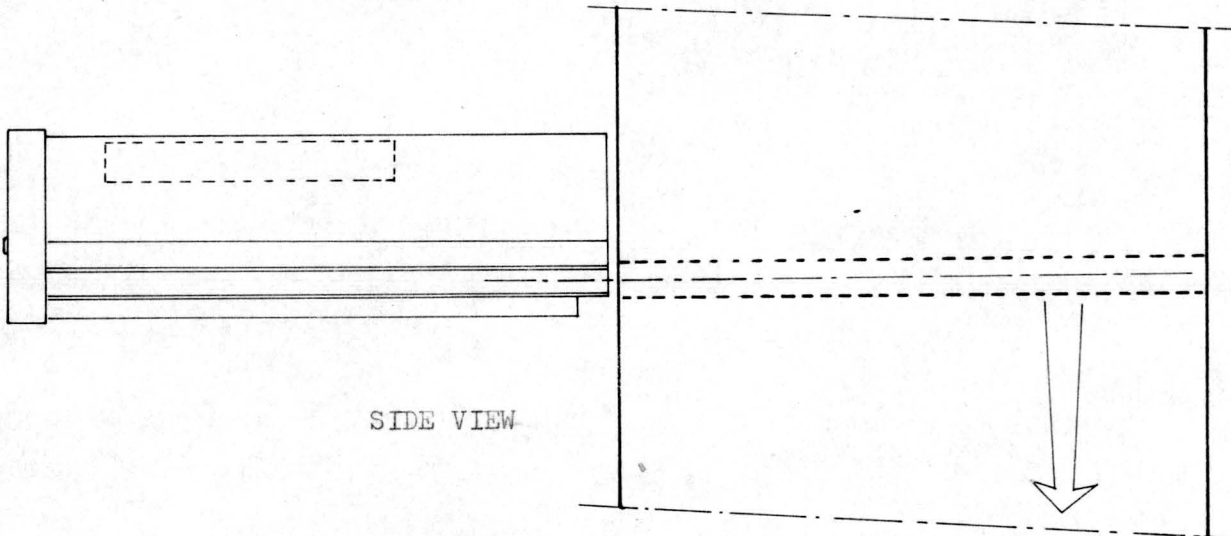

SIDE VIEW

direction of
required balance
force

X 1210 IN MAINTENANCE POSITION

FIGURE 5.(2)

status		supers doc.no.	dept. Prod.planning
REV.	B		
N.V. PHILIPS - ELECTROLOGICA I.G. Peripheral Equipment			date 70-03-12
			page 5-6

ENGINEERING SPECIFICATION X 1210

doc.no.
reg.no. CNO/70/03005/523
distribution

6. OPTIONS

6.1. General

The following options, which are described in detail on the following pages, are available for use with the X 1210 mono disk drive.

<u>As storage media:</u>	<u>described in paragraph:</u>
XXM 1416 mono disk cartridge (16 sectors)	6.2
XXM 1424 mono disk cartridge (24 sectors)	6.2

For installation in a 19 inch rack:

XXM 1405 rack unit slides	6.3
XXM 1406 rack unit cable guide	6.4
XXM 1407 power supply unit	6.5

For maintenance:

XXM 1408 tester module	6.6
XXM 1409 mono disk exerciser	6.7
XXM 1410 C.E. cartridge	6.8

Miscellaneous:

Handbook	6.9
----------	-----

All rights strictly reserved. Reproduction or issue to third parties in any form whatsoever is not permitted without written authority from the proprietors.

Eigendom van: N.V. PHILIPS - ELECTROLOGICA Apeldoorn
Property of: N.V. PHILIPS - ELECTROLOGICA Nederland

Alle rechten uitdrukkelijk voorbehouden. Vermenigvuldiging of mededeling aan derden, in welke vorm ook, is zonder schriftelijke toestemming van eigenares niet geoorloofd.

status	supers doc.no.	dept	Prod.Planning
		author	
		date	71-07-09
		page	6-1
N.V. PHILIPS - ELECTROLOGICA I.G. Peripheral Equipment			

ENGINEERING SPECIFICATION X 1210

doc.no.

reg no.

CNO/70/03005/523

distribution

- 6.2 Mono disk cartridge
 - Contents
 - 6.2.1 General
 - 6.2.2 Performance characteristics
 - 6.2.3 Interfaces
 - 6.2.4 Operation
 - 6.2.5 Technical characteristics

All rights strictly reserved. Reproduction or issue to third parties in any form whatever is not permitted without written authority from the proprietors.

Eigendom van: Property of
N.V. PHILIPS - ELECTROLOGICA
Apeldoorn Nederland

Alle rechten uitdrukkelijk voorbehouden. Vermenigvuldiging of mededeling aan derden, in welke vorm ook, is zonder schriftelijke toestemming van eigenares niet geoorloofd.

status		supers doc.no.	dept	Prod.Planning	
			author		
		N.V. PHILIPS - ELECTROLOGICA		date	71-07-09
		I.G. Peripheral Equipment		page	6-2

6.2.1 General

The XMX 1416 and XMX 1424 disk cartridges are designed as removable and interchangeable random access memory media for mono disk drive units. Depending on the number of radial slots in the sector ring available, the cartridge is designated as:

XMX 1416 for a 16 slots model and
XMX 1424 for a 24 slots model

Both models are further on referred as mono disk cartridge. The disk used in the cartridge is an industry standard 14 inch type, enabling high bit density recording with "flying" read/write heads.

The cartridge can be installed with simple locking and disconnecting actions.

The disk is protected from dust and other contaminants and mechanical damage by a plastic envelop enclosing the disk permanently. The read/write heads enter the cartridge through a single opening which is always automatically closed with a sliding door when the cartridge is removed from the disk drive.

6.2.2 Performance characteristics

6.2.2.1 Characteristics

The cartridge has following characteristics:

type	: removable
nr. of disks	: one
nr. of recording surfaces	: two
nr. of tracks/surface	: 200 + 4 spares
nr. of sectors	: 16 and 24
index marker	: one per revolution of the disk
disk velocity	: 770 up to 2500 rpm
recording density	: 2200 bits/inch on a track diameter of 230.000 mm.
storage capacity	: depending of disk drive and formatting approx. 2,5 Mbyte
surface errors	: the entire area (all recordable tracks) of the disk is free of errors

status	supers doc.no.	dept	Prod.Planning
		author	
		date	71-07-09
		page	6-3
N.V. PHILIPS - ELECTROLOGICA I.G. Peripheral Equipment			

6.2.2.2 Compatibility

For the interchange of data the mono disk cartridges are interchangeable with themselves and operate with all compatible mono disk drives.

6.2.2.3 Reliability

Reliable operation of the cartridge depends on the following factors:

meantime between failure
preventive maintenance time
meantime to repair
data security time
service life

6.2.2.3.1 Meantime between failure

Definition - The MTBF is expressed by the following equation:

$$MTBF = \frac{\text{Nr. of operating hours}}{\text{Nr. of cartridge failures}}$$

Operating hours mean operating hours with disk rotating in the cartridge.

Equipment failures mean any stoppage or substandard performance because of cartridge malfunction and requiring unscheduled maintenance, excluding stoppages or substandard performance caused by operator error, adverse environment, wrong speed or other failure not caused by the cartridge. Essentially the term cartridge failure implies that emergency maintenance is required because of hardware failure or substandard performance.

MTBF - The MTBF will exceed 12000 hours.

6.2.2.3.2 Preventive maintenance time

Definition - The routine preventive maintenance shall be performed by suitably trained and competent customer personnel or service men.

PMT - The routine scheduled preventive maintenance time will not exceed 15 minutes per 1600 operating hours.

6.2.2.3.3 Meantime to repair

Definition - The MTTR is the average time an adequately trained and competent Customer Engineer will need to diagnose and correct a cartridge malfunction.

MTTR - The MTTR will not exceed one hour.

All rights strictly reserved. Reproduction or issue to third parties in any form whatsoever is not permitted without written authority from the proprietor.

Eigendom van:
N.V. PHILIPS-ELECTROLOGICA
Apeldoorn
Property of
NEDERLAND

Alle rechten uitsluitend voorbehouden.
Vernieuwing of mededeling aan
derden, in welke vorm ook, is zonder
schriftelijke toestemming van eigenaar
niet geoorloofd.

status	supers doc.no.	dept Prod.Planning
		author
	N.V. PHILIPS - ELECTROLOGICA	date 71-07-09
	I.G. Peripheral Equipment	page 6-4

ENGINEERING SPECIFICATION X 1210

doc.no.
reg.no. CNO/70/03005/523
distribution

All rights strictly reserved. Reproduction in any form to third parties in any form whatever is not permitted without written authority from the proprietors.

6.2.2.3.4 Data security time

Definition - The DST is the time that once written data, is under normal circumstances, altered in such a way that it must be rewritten. It is not allowed to expose the cartridge to high-intensity external magnetic fields.
DST - The DST will exceed 10 years.

6.2.2.3.5 Service life

Definition - The service life is the number of operating hours, before factory disassembling, test, cleaning, re-assemble, balancing and test on a drive is required. Repair or replacement of parts will be permitted during the life time.
Service life - The cartridge will provide a useful life of five years or 24.000 hours, whichever occurs first.

6.2.3 Interfaces

6.2.3.1 Electrical interface

Neither electric power nor electronic signals are required to operate the cartridge. Driving the disk and sensing the sector slots is a function of the mono disk drive.

6.2.3.2 Mechanical interface

The cartridge fits mechanically in any compatible mono disk drive. More details are given in para 6.2.5.

6.2.4 Operation

6.2.4.1 Operating procedure

Before a cartridge is used it shall be conditioned in the same environment in which the disk drive operates, however, with a temperature within 10 to 32° C for two hours prior to use, to ensure correct track registration.
At the top of the cartridge an interlock handle is placed, which permits quick securing and removal of the cartridge to and from the disk drive.
To install the cartridge move the handle to the upper position, prepare the disk drive to receive the cartridge and place the cartridge. Turn the locking ring on the disk drive and pull the handle forward until it lies down on the top cover. The cartridge fits in the disk drive only in one way. To remove the cartridge, move the cartridge locking handle to the upper position and push it backwards until it stops.

Property of
N.V. PHILIPS - ELECTROLOGICA
Nederland
Apeldoorn

Alle rechten, uitdrukkelijk voorbehouden.
Vernietigvuldiging of mededeling aan
derden, in welke vorm ook, is zonder
schriftelijke toestemming van eigenares
niet geoorloofd.

status	supers doc.no.	dept Prod.Planning
		author
	N.V. PHILIPS - ELECTROLOGICA I.G. Peripheral Equipment	date 71-07-09
		page 6-5

All rights strictly reserved. Reproduction or issue to third parties in any form whatever is not permitted without written authority from the proprietors.

Eigendom van: Property of
N.V. PHILIPS - ELECTROLOGICA
Apeldoorn Nederland

Alle rechten uitdrukkelijk voorbehouden. Vermenigvuldiging of mededeling aan derden, in welke vorm ook, is zonder schriftelijke toestemming van eigenares niet geoorloofd.

6.2.4.1 (Continued)

Then turn the disk drive unit locking ring and lift the cartridge by means of the handle out of the unit. Lay the handle down and store the cartridge in a clean, dry location.

6.2.4.2 Cartridge handling precautions.

The cartridge is specifically designed to prevent entering of dust etc., therefore the access door has a positive stop and may never be opened when the cartridge is outside the disk drive. Also the disk hub is pressed against the bottom cover to avoid entering of dust etc. The cartridges may be stored on edge, however, it must be done with care to avoid damage to the hub and sector slots. It may be considered that, when placing the cartridge on a flat surface, it is free of other objects. It is not allowed to remove a cartridge when the disk is not completely stopped.

6.2.4.3 Cartridge labeling

The cartridge is provided with a molded frame (on the front edge) that is designed to hold an exchangeable label without the use of adhesives.

6.2.5 Technical characteristics.

6.2.5.1 Physical description.

The cartridge is a type which must be locked in the mono disk drive with a locking ring with three cams. The approximate dimensions of the cartridge are:

diameter : 400 mm
height : 50 mm

Weight of the cartridge is less than 2,5 kg. The air pressure in the cartridge shall be slightly above environmental air pressure to prevent air and therefore contaminants to enter the cartridge. For this purpose the mono disk drive supplies filtered air for the cartridge through the access opening. The handle of the cartridge is intended for removal and installation and short duration transport. Shipping shall be done in a special container to protect against mechanical damage. The cartridge may be in a horizontal plane or on the edge. The cartridge envelop is made of high impact resistant self extinguishing material providing protection against dust and impact. The cartridge is assembled under clean conditions.

status		supers doc.no.	dept	Prod.Planning	
			author		
		N.V. PHILIPS - ELECTROLOGICA		date	71-07-09
		I.G. Peripheral Equipment		page	6-6

ENGINEERING SPECIFICATION X 1210

doc.no.
reg.no. CNO/70/03005/523
distribution

6.2.5.2 Environmental conditions

6.2.5.2.1 General

The cartridge will withstand the following environmental conditions without damage or down graded performance.

6.2.5.2.2 Climatic conditions

- Environmental temperature
 - Operating : 10 to 32°C (also short storage)
 - Operating : When operating in a temperature range of 5 to 40°C, the cartridge may work not satisfactorily or with down graded performance, but shall not be damaged.
 - Non-operating: - 40 to 65°C
- Temperature acclimatisation
 - The cartridge shall be in an area with a temperature within the operating environmental range at least two hours prior to use.
- Thermal shock
 - Operating : maximum 15°C hour
 - Non-operating: maximum 30°C hour
- Humidity
 - Relative humidity providing there is no condensation
 - Operating : 10 to 80%
 - Non-operating: 5 to 85%
- Heat radiation
 - Direct sunlight on the cartridge is not allowed
- Moisture
 - Water exposure is not allowed
- Dust and sand
 - The area in which the cartridge is present, must be free of dust and sand, as usual in office rooms.
- Air pressure
 - Operating : 1 bar, +5 to -25% (equal to about 750 ft below and 8000 ft above mean sea level)
 - Non-operating: 1 bar, +5 to -50% (equal to about 750 ft below and 18.000 ft above mean sea level)

All rights strictly reserved. Reproduction or issue to third parties in any form whatever is not permitted without written authority from the proprietors.

Property of
N.V. PHILIPS - ELECTROLOGICA
Nederland
Apeldoorn

Alle rechten uitdrukkelijk voorbehouden.
Vernietiging of mededeling aan
derden, in welke vorm ook, is zonder
schriftelijke toestemming van eigenares
niet geoorloofd.

status	supers doc.no.	dept	Prod.Planning
		author	
		date	71-07-09
		page	6-7
N.V. PHILIPS - ELECTROLOGICA I.G. Peripheral Equipment			

ENGINEERING SPECIFICATION X1210

doc.no.

reg.no.
CN0/70/03005/523

distribution

6.2.5.2.3 Mechanical conditions

- Vibration
 - Operating: no vibration of any importance is allowed
 - Non-operating: a peak displacement of $\pm 0,13$ mm for the frequency range from 10 to 60 Hz and ± 2 g 's for the range from 60 to 500 Hz
- Shock
 - Operating: no shocks of any importance are allowed
 - Non-operating: 18 impact shocks of 5 g, $\pm 10\%$ consisting of three shocks in opposite directions along each of three mutually perpendicular axes. Each shock impulse shall have a time duration of $11, \pm 1$ msec.
- Acceleration
 - Operating: no acceleration of any importance is allowed
 - Non-operating: see para. Vibration and Shock.

6.2.5.2.4 Shipping and storage

- Shipping
 - The equipment itself shall not be subject to conditions worse than specified under 6.2.5.2.2 and 6.2.5.2.3.

Vibration: the packed unit will withstand a peak displacement of 20 mm at a frequency of 5 vibrations per sec. and an acceleration of 1 g on the vertical axis, during one hour.

Shock: no damage will occur to the cartridge when the shipping container with cartridge is dropped repeatedly from a height of 122 cm.

- Storage
 - The equipment itself shall not be subject to conditions worse than specified in 6.2.5.2.2 and 6.2.5.2.3.
 - When the unit has been stored for a time longer than 6 months, a technical inspection, as described in the concerning maintenance manual should be performed before the unit is put into operation.

Short term storage: cartridges that are in frequent use should be stored in the disk drive room environment. The recommended conditions are: temperature 10 to 32°C, rel. humidity 10 to 80%.

All rights strictly reserved. Reproduction or issue to third parties in any form whatever is not permitted without written authority from the proprietor.

Eigendom van: Property of
N.V. PHILIPS - ELECTROLOGICA
Apeldoorn Nederland

Alle rechten uitsluitend voorbehouden. Vermenigvuldiging of mededeling aan derden, in welke vorm ook, is zonder schriftelijke toestemming van eigenares niet geoorloofd.

status	supers doc.no.	dept Prod.Planning
		author
	N.V. PHILIPS - ELECTROLOGICA I.G. Peripheral Equipment	
		date 71-07-09
		page 6-8

ENGINEERING SPECIFICATION X1210

doc.no.

reg.no.
CN0/70/03005/523

distribution

Long term storage: it is advised to store cartridges in the original shipping containers. The temperature shall remain within -40 to $+65^{\circ}\text{C}$.

6.2.5.2.5 Magnetic field distortion

The cartridge shall never be exposed to intense magnetic fields. A stray field intensity of more than 50 gauss may cause loss of information.

6.2.5.2.6 Chemical conditions

The cartridge will resist to 91% isopropyl alcohol (9% water) used as a cleaning solvent in customer installations.

6.2.5.3 Mechanical description

The cartridge consists of a single recording disk and hub assembly which are enclosed in the top and bottom covers. The bottom cover fits only in one way into a cartridge holder on top of the mono disk drive.

The top cover contains one access door to provide entrance for read/write heads and cleaning brushes. The brushes (part of the mono disk drive) sweep dust and dirt particles from the recording surfaces.

The recording disk consists of an aluminium base material and is coated with a layer of ferro magnetic material suspended in a binder. This layer will withstand the effect of floating read/write heads during normal operation.

The disk is by means of a cone in the hub assembly accurately positioned on the top of the mono disk drive spindle. A mechanical latch clamps the disk hub and the drive spindle together with the help of a spring.

The hub assembly is provided with holes in the bottom which mate with spring loaded pins on the spindle assembly. This construction enables short start and stop times.

The hub assembly is provided with a ring containing slots to indicate begin of tracks and of sectors on the disk and to determine disk speed.

All rights strictly reserved. Reproduction or issue to third parties in any form whatsoever is not permitted without written authority from the proprietors.

Eigendom van: N.V. PHILIPS - ELECTROLOGICA Apeldoorn
Property of: N.V. PHILIPS - ELECTROLOGICA Nederland

Alle rechten ultrakwelijk voorbehouden. Vermenigvuldiging of mededeling aan derden, in welke vorm ook, is zonder schriftelijke toestemming van eigenaar niet geoorloofd.

status		supers doc.no.	dept Prod.Planning
			author
		N.V. PHILIPS - ELECTROLOGICA I.G. Peripheral Equipment	date 71-07-09
			page 6-9

ENGINEERING SPECIFICATION X 1210

doc.no.

reg.no.

CNO/70/03005/523

distribution

6.2.5.3 Continued

The handle on the cartridge serves either as a carrying handle or as a lever to overcome the holding force of the spring.

The cartridge is assembled under clean conditions. After final assembling the disk surface is checked for errors and certified as error free.

All rights strictly reserved. Reproduction or issue to third parties in any form whatever is not permitted without written authority from the proprietors.

Eigendom van: Property of
N.V. PHILIPS - ELECTROLOGICA
Apeldoorn Nederland

Alle rechten uitsluitend voorbehouden. Vermenigvuldiging of mededeling aan derden in welke vorm ook, is zonder schriftelijke toestemming van eigenares niet geoorloofd.

status		supers doc.no.	dept	Prod.Planning
			author	
			date	71-07-09
			page	6-10
N.V. PHILIPS - ELECTROLOGICA I.G. Peripheral Equipment				

ENGINEERING SPECIFICATION X 1210

doc.no.

reg.no.

distribution

6.3 Rack unit slides

Contents

6.3.1 Description

All rights strictly reserved. Reproduction or issue to third parties in any form whatsoever is prohibited without written authority from the proprietors.

Eigendom van:
N.V. PHILIPS - ELECTROLOGICA
Apeldoorn
Nederland

Alle rechten uitsluitend voorbehouden. Het verspreiden of afgeven van afschriften of andere vormen van openbaarmaking van de inhoud van dit document is zonder schriftelijke toestemming van eigenaars niet geoorloofd.

status		supers doc.no.	dept Prod.Planning
			author
		N.V. PHILIPS - ELECTROLOGICA I.G. Peripheral Equipment	date 71-07-09
			page 6-11

ENGINEERING SPECIFICATION X 1210

doc.no.
reg.no. CNO/70/03005/523
distribution

6.3.1 Description

The XMX 1405 rack unit slides are designed to provide three alternative positions of the X 1210 in the 19" rack unit. The slides are provided with brackets to mount them in the rack unit.

The three positions are:

- Operational position - this is the read/write position, i.e. the X 1210 is completely in the rack, its front panel being flush with the rack. The drive is maintained in this position by a brake mechanism.
- Cartridge exchange position for cartridge installation or removal the drawer is partly withdrawn from the rack until further withdrawal is limited by the slide stops
- servicing position when both detent levers on the slides are unlatched, the X 1210 can be withdrawn completely clear of the rack. The top and bottom covers can be removed now to service the X 1210. The slides are locked in this position. To push the X 1210 back in the rack, the detent levers must be unlatched.

Weight of the slides is approximately kg

All rights strictly reserved. Reproduction in any form whatsoever is not permitted without written authority from the proprietors.

Eigendom van: Property of
N.V. PHILIPS - ELECTROLOGICA
Apeldoorn Nederland

Alle rechten uitdrukkelijk voorbehouden. Vermenigvuldiging of mededeling aan derden, in welke vorm ook, is zonder schriftelijke toestemming van eigenares niet geoorloofd.

status	supers doc.no.	dept	Prod.Planning
		author	
		date	71-07-09
		page	6-12
N.V. PHILIPS - ELECTROLOGICA I.G. Peripheral Equipment			

ENGINEERING SPECIFICATION X 1210

doc.no.

reg.no.

CNO/70/03005/523

distribution

6.4 Rack unit cable guide

6.4.1 Description

All rights strictly reserved. Reproduction in any form is prohibited, in any form whatever is not permitted without written authority from the proprietors.

Eigendom van: Property of
N.V. PHILIPS - ELECTROLOGICA
Apeldoorn Nederland

Alle rechten uitdrukkelijk voorbehouden. Vermenigvuldiging of mededeling aan derden, in welke vorm ook, is zonder schriftelijke toestemming van eigenares niet geoorloofd.

status		supers doc.no.	dept Prod.Planning
			author
		N.V. PHILIPS - ELECTROLOGICA	date 71-07-09
		I.G. Peripheral Equipment	page 6-13

ENGINEERING SPECIFICATION X 1210

doc.no.

reg.no.

CNO/70/03005/523

distribution

6.4.1 Description

The XMX 1406 rack unit cable guide provides a safe and flexible means of maintaining the supplies and control signals to the X 1210 whilst withdrawn to the cartridge exchange or servicing position. The power and signal cables are included in this option. The length of each cable is 3 meters. At the X 1210 side of the cables, two connectors are provided to supply power and control signals to the X 1210.

The other end of the supplies cables are also provided with connectors mating with the XMX 1407 receptacles for A.C. and D.C. power output. The other end of the I/O signal cables are not terminated with connectors.

Weight of the complete cable guide is approximately ... kg

All rights strictly reserved. Reproduction or issue to third parties without written authority from the proprietors.

Eigendom van:
N.V. PHILIPS - ELECTROLOGICA
Apeldoorn
Nederland

Alle rechten uitdrukkelijk voorbehouden. Vermenigvuldiging of mededeling aan derden, in welke vorm ook, is zonder schriftelijke toestemming van eigenaars niet geoorloofd.

status		supers doc.no.	dept Prod.Planning
			author
		N.V. PHILIPS - ELECTROLOGICA I.G. Peripheral Equipment	date 71-07-09
			page 6-14

ENGINEERING SPECIFICATION X 1210

doc.no.

reg no.

CNO/70/03005/523

distribution

6.5. Power supply unit

Contents

- 6.5.1 General
- 6.5.2 Performance characteristics
- 6.5.3 Interface
- 6.5.4 Operation
- 6.5.5 Technical characteristics

All rights strictly reserved. Reproduction in any form to third parties, in whatever is not permitted without written authority from the proprietors.

Eigendom van: Property of
N.V. PHILIPS - ELECTROLOGICA
Apeldoorn Nederland

Alle rechten uitsluitend voorbehouden. Vermenigvuldiging of mededeling aan derden, in welke vorm ook, is zonder schriftelijke toestemming van eigenares niet geoorloofd.

status		supers doc.no.	dept Prod.Planning
			author 1
N.V. PHILIPS - ELECTROLOGICA I.G. Peripheral Equipment			date 71-07-09
			page 6-15

6.5.1 General

The XMX 1407 power supply unit is designed for installation in a standard 19" rack unit. It supplies one X 1210 with + 5V, -12V and + 24V stabilized D.C. and 220 V single phase A.C. It operates from a 220V single phase A.C. supply.

6.5.2 Performance characteristics6.5.2.1 A.C. power output

The power supply unit delivers the following A.C. power, which is in fact the same as on the input, however, filtered and fused.

- Voltage : 220 Vrms nominal, one phase with safety earth;

limits for voltages higher than nominal value:

- a. 10% from nominal value
- b. between 10% and 15%, provided that duration is not longer than 10 sec., with a duty cycle of maximum 1 : 20

limits for voltages lower than nominal value:

- a. 10% from nominal value
- b. between 10% and 15%, provided that duration is not longer than 10 sec., with a duty cycle of maximum 1 : 20
- c. any value during maximum 10 msec., with a repetition rate of less than one per sec.

- Distortion : maximum linear harmonic distortion 10%

- Frequency : 50 Hz nominal, $\pm 2\%$

- Current : 1,0 Amp. worst case continuous
2,5 Amp. during start (2 sec.)

6.5.2.2 D.C. power output

The power supply unit delivers following D.C. power at the D.C. output connector:

- output voltage LV1- voltage: + 5V nominal

-current :-for X 1210 mono disk drive

1,5 Amp. worst case continuous

2,0 Amp. intermittent

- for XMX 1409 mono disk exerciser

0,8 Amp. worst case continuous

status	supers doc.no.	dept. Prod.Planning
		author
	N.V. PHILIPS - ELECTROLOGICA I.G. Peripheral Equipment	date 71-07-09
		page 6-16

All rights strictly reserved. Reproduction or issue to third parties in any form whatever is not permitted without written authority from the proprietors.

Eigendom van: Property of
N.V. PHILIPS - ELECTROLOGICA
Apeldoorn Nederland

Alle rechten uitdrukkelijk voorbehouden. Vermenigvuldiging of mededeling aan derden, in welke vorm ook, is zonder schriftelijke toestemming van eigenares niet geoorloofd.

- output voltage LV2-voltage : -12V nominal
-current : 0,3 Amp. worst case continuous
- output voltage LV3-voltage: + 24V nominal
2,0 Amp. worst case continuous
3,3 Amp. intermittent
- regulation : - all D.C. output voltages remain within $\pm 5\%$ from the nominal values, including both RMS and instantaneous noise spikes, turn-on and turn-off overshoots and accidental A.C. input power removals.
- protection : - each output voltage will be limited when the load currents exceed 120% of the maximum load currents. The output voltages automatically restore to normal when overloads are removed.
- the + 5V output line is sensed by an overvoltage "crow bar" protector. When the output voltage exceeds + 6V, the output is clamped to about + 0,8 V. The unit must be switched of to restore to normal operation.

6.5.2.3 Reliability

The reliability of the power supply unit is determined by the following:

- meantime between failure (MTBF)
- meantime to repair (MTTR)
- preventive maintenance time (PMT)
- service life.

6.5.2.3.1 Meantime between failure

Definition.- The MTBF is expressed by the following equation:

$$MTBF = \frac{\text{Nr. of operation hours}}{\text{Nr. of equipment failures}}$$

Operating hours means total time, less maintenance time. Equipment failures mean any stoppage or substandard performance of the equipment because of equipment malfunction and/or requiring unscheduled maintenance, excluding stoppage or substandard performance caused by operating error, adverse environment, input power failure or output load failure or other failure not caused by the equipment itself.

status	supers doc.no.		dept Prod.Planning
			author
		N.V. PHILIPS - ELECTROLOGICA I.G. Peripheral Equipment	date 71-07-09
			page 6-17

Essentially the term equipment failures implies that emergency maintenance is required because of hardware failure or substandard performance.

MTBF.- Following an initial period of 200 hours, the MTBF will exceed 5.000 hours.

6.5.2.3.2 Meantime to repair

Definition.- The MTTR is the average time an adequately trained and competent serviceman will need to diagnose and correct an equipment malfunction.

MTTR.- The MTTR following the initial 200 operating hours will be less than $\frac{1}{2}$ man-hours.

6.5.2.3.3 Preventive maintenance time

Definition.- The routine preventive maintenance will be performed by suitably trained and competent customer personnel or serviceman. The schedule for preventive maintenance will be based on procedures recommended by I.G.P.E.

PMT.- The routine scheduled preventive maintenance time will not exceed one man-hour per 2500 operating hours.

6.5.2.3.4 Service life

Definition.- The service life is the number of operating hours, before factory overhaul or replacement is required. Repair or replacement of major parts will be permitted during the life time.

Service life- The power supply unit is designed and constructed to provide an useful life of five years or 24.000 hours, whichever occurs first.

6.5.3 Interfaces

6.5.3.1 Power input interface

The power supply unit operates within the performance limits when the following A.C. line power is supplied to the unit:

- Voltage : 220 Vrms nominal, one phase with safety earth; limits for voltages higher than nominal value:
 - a. 10% from nominal value
 - b. between 10% and 15%, provided that duration is not longer than 10 sec., with a duty cycle of maximum 1 : 20
- limits for voltages lower than nominal value:
 - a. 10% from nominal value
 - b. between 10% and 15%, provided that duration is not longer than 10 sec., with a duty cycle of maximum 1 : 20
 - c. any value during maximum 10 msec., with a repetition rate of less than one per sec.

status

supers doc.no.

dept Prod.Planning

author

N.V. PHILIPS - ELECTROLOGICA
I.G. Peripheral Equipment

date 71-07-09

page 6-18

ENGINEERING SPECIFICATION X 1210

doc.no.

reg.no.

CNO/70/03005/523

distribution

All rights strictly reserved. Reproduction or issue to third parties in any form whatever is not permitted without written authority from the proprietors.

- Distortion : maximum linear harmonic distortion 10%, further the line must be free of transient signals which might create read errors in the disk drive.
- Frequency : 50 Hz nominal, $\pm 2\%$
- Current : nominal approximately 1,5 Amp.

6.5.3.2 Connectors

A schematic diagram of the interface connectors and associated internal components is given in fig. 6.5.(1).

6.5.3.3 A.C. power input interface connector

The A.C. power to the power supply unit will be supplied by means of a cable from the mains power connection. The cable will be attached to the unit by means of a CANNON connector.

Connectors:

receptacle on the unit: MS3102E20-17P
 plug at the cable : MS3106E20-17S(C) (straight type)*
 with clamp AN3057-10

* Note: This connector is supplied with the power supply unit and packed in the unit in a plastic bag.

Wiring

<u>wire assignment</u>	<u>contact assignment</u>
220 VAC (line)	C
shield	B
spare	D
220 VAC (neutral)	E
safety earth	A
spare	F

6.5.3.4 A.C. power output interface connector

The A.C. power to the disk drive unit will be supplied by means of a cable from the XMX 1407 power supply unit. The cable will be attached to the unit by means of a CANNON connector.

Connectors:

receptacle on the unit: MS3102E20-17S(C)
 plug at the cable : MS3106E20-17P (straight type) ')
 with clamp AN3057-10

') Note: This connector is part of option XMX 1406.

Eigendom van: Property of
 N.V. PHILIPS - ELECTROLOGICA
 Apeldoorn Nederland

Alle rechten uitdrukkelijk voorbehouden. Vermenigvuldiging of mededeling aan derden, in welke vorm ook, is zonder schriftelijke toestemming van eigenares niet geoorloofd.

status	supers doc.no.	dept Prod.Planning
		author
	N.V. PHILIPS - ELECTROLOGICA	date 71-07-09
	I.G. Peripheral Equipment	page 6-19

ENGINEERING SPECIFICATION X 1210

doc.no.

reg.no.

distribution

Wiring:

<u>wire assignment</u>	<u>contact assignment</u>
220 VAC (hot)	C
spare	B
spare	D
220 VAC (neutral)	E
safety earth	A
spare	F

6.5.3.5 D.C. power output interface connector

The D.C. power to the disk drive unit will be supplied by means of a cable from the XMX 1407 power supply unit. The cable will be attached to the unit by means of a SOCAPEX connector.

Connector:

receptacle on the unit: E 67-18AX
 plug at the cable : FD67-18AX ')

') Note: This connector is part of option XMX 1406

Wiring:

<u>wire assignment</u>	<u>contact assignment</u>
return (+ 24V)	1
	2
	3
return (+ 5V)	4
	5
+ 12 V	6
	7
+ 24 V	8
	9
+ 5V	10
	11
return (+12V)	12
spare	13
spare	14
spare	15
spare	16
spare	17
spare	18

6.5.3.6 Grounding terminal

One separate grounding terminal, connected to the frame, is provided at the rear of the unit, as an extra safety earth connection.

All rights strictly reserved. Reproduction or issue to third parties in any form whatever is not permitted without written authority from the proprietors.

Eigendom van: N.V. PHILIPS - ELECTROLOGICA Apeldoorn
 Property of: N.V. PHILIPS - ELECTROLOGICA Nederland

Alle rechten uitdrukkelijk voorbehouden. Vermenigvuldiging of mededeling aan derden, in welke vorm ook, is zonder schriftelijke toestemming van eigenaars niet geoorloofd.

status	supers doc.no.	dept. Prod.Planning
		author
N.V. PHILIPS - ELECTROLOGICA I.G. Peripheral Equipment		date 71-07-09
		page 6-20

6.5.4 Operation.

The operation of the power supply unit is by means of one switch and one indicator on the front panel. When the part of the switch which is the nearest to the indicator is pushed, the indicator will light, to indicate that the unit is switched on.

Note: For normal operation the disk drive unit must be in the STOP condition prior to turning off A.C. and D.C. power by means of the switch.

6.5.5 Technical characteristics6.5.5.1 Physical description.

The dimensions of the power supply unit are given in fig. 6.5(2).

Weight of the unit with accessories is approximately 18 kg. No forced air cooling is required. The bottom and top sides of the unit must have sufficient space with respect to other equipment to allow air cooling by convection. For this purpose the unit must be mounted horizontally.

6.5.5.2 Environmental conditions6.5.5.2.1 General

The power supply unit will withstand the following environmental conditions, without damage or degradation of output rating or any other specification.

6.5.5.2.2 Climatic conditions

- Environmental temperature

Operating : + 0 to + 55°C
Nonoperating : - 35 to + 65°C

- Thermal shock

Operating : maximum 11°C per hour
Nonoperating : maximum 22°C per hour

- Temperature acclimatization

Before the equipment is turned on, the equipment shall be in an area with a temperature within the operating environmental range for at least two hours.

status	supers doc.no.	dept. Prod.Planning
		author
	N.V. PHILIPS - ELECTROLOGICA I.G. Peripheral Equipment	date 71-07-09
		page 6-21

ENGINEERING SPECIFICATION X 1210

doc.no.
reg.no. CNO/70/03005/523
distribution

All rights strictly reserved. Reproduction or issue to third parties in any form whatever is not permitted without written authority from the proprietors.

Eigendom van: Property of
N.V. PHILIPS - ELECTROLOGICA
Apeldoorn Nederland

Alle rechten uitdrukkelijk voorbehouden. Vermenigvuldiging of mededeling aan derden, in welke vorm ook, is zonder schriftelijke toestemming van eigenares niet geoorloofd.

- Humidity
 - Relative humidity, providing there is no condensation
 - Operating : 20 to 80 %
 - Nonoperating : 5 to 90 %
- Heat radiation
 - Direct sunlight radiation on the power supply unit is not allowed. The requirement does not apply when the unit is installed in a closed 19 inch rack.
- Moisture
 - Water exposure is not allowed.
- Dust and sand
 - The installation area of the power supply unit must be free of sand and dust, as usual in office rooms.
- Air pressure
 - Operating : 1 bar, + 5 to -30%. This pressure is equal to about 750 feet below and 10.000 feet above mean sea level.
 - Nonoperating : 1 bar, + 5 to -50%. This pressure is equal to about 750 feet below and 18.000 feet above mean sea level.

6.5.5.2.3 Mechanical conditions

- Vibration
 - Operating : no vibration of any importance is allowed.
 - Nonoperating : a peak displacement of $\pm 0,13$ mm for the frequency range from 10 to 60 Hz and ± 2 g's for the range from 60 to 500 Hz
- Shock
 - Operating : no shocks of any importance are allowed .
 - Nonoperating : 18 impact shocks of $5 g, \pm 10\%$ consisting of three shocks in opposite directions along each of three mutually perpendicular axes. Each shock impulse shall have a time duration of $11, \pm 1$ msec.

status	supers doc.no.	dept. Prod.Planning
		author
	N.V. PHILIPS - ELECTROLOGICA I.G. Peripheral Equipment	date 71-07-09
		page 6-22

- Acceleration

- Operating : no acceleration of any importance is allowed.
- Nonoperating : see para Vibration and Shock.

6.5.5.2.4 Shipping and storage conditions**- Shipping**

The equipment itself shall not be subject to conditions worse than specified under 6.5.5.2.2 and 6.5.5.2.3.

Vibration : the packed unit will withstand a peak displacement of 20 mm at a frequency of 5 vibrations per sec. and an acceleration of 1 g on the vertical axis, during one hour.

Shock : the packed unit will withstand the following test, performed on the four sides of the unit. The packed unit is fastened to a carriage, which rolls off a slope with a gradient of 10° over a distance of 1,5 m, against a stone wall.

- Storage

The equipment itself shall not be subject to conditions worse than specified in 6.5.5.2.2 and 6.5.5.2.3.

When the unit has been stored for a time longer than 6 months, a technical inspection, as described in the concerning maintenance manual should be performed before the unit is put into operation.

6.5.5.3 Mechanical description

The unit consists basically of a metal framework in which three Philips power supply modules and one overvoltage "crow-bar" protection are mounted, together with a main fuse and switch and a filter. Connectors are provided at the rear of the unit. Separate items delivered with the unit are spare fuses, mounting slides and bolts.

6.5.5.4 Electrical description

All voltage lines are brought out to the output connectors separately.

status		supers doc.no.	dept. Prod. planning
			author
		N.V. PHILIPS - ELECTROLOGICA I.G. Peripheral Equipment	date 71-07-09
			page 6-23

ENGINEERING SPECIFICATION X 1210

doc.no.

reg.no.

CNO/70/03005/523

distribution

6.5.5.4 Continued

The return lines are not bussed together in the unit. Safety earth is provided in the A.C. power input connector and is not connected to any output voltage line. Adjustments are provided for the purpose of adjusting the voltage regulators and overload protection circuits.

All rights strictly reserved. Reproduction or issue to third parties in any form whatever is not permitted without written authority from the proprietors.

Eigendom van: Property of
N.V. PHILIPS - ELECTROLOGICA
Apeldoorn Nederland

Alle rechten uitdrukkelijk voorbehouden. Vermenigvuldiging of mededeling aan derden, in welke vorm ook, is zonder schriftelijke toestemming van eigenaars niet geoorloofd.

status		supers doc.no.	dept. Prod.Planning
			author
		N.V. PHILIPS - ELECTROLOGICA I.G. Peripheral Equipment	date 71-07-09
			page 6-24

All rights strictly reserved. Reproduction or issue to third parties in any form whatever is not permitted without written authority from the proprietors.

Eigendom van: N.V. PHILIPS - ELECTROLOGICA Apeldoorn Nederland

Alle rechten uitdrukkelijk voorbehouden. Vermenigvuldiging of mededeling aan derden, in welke vorm ook, is zonder schriftelijke toestemming van eigenaar niet geoorloofd.

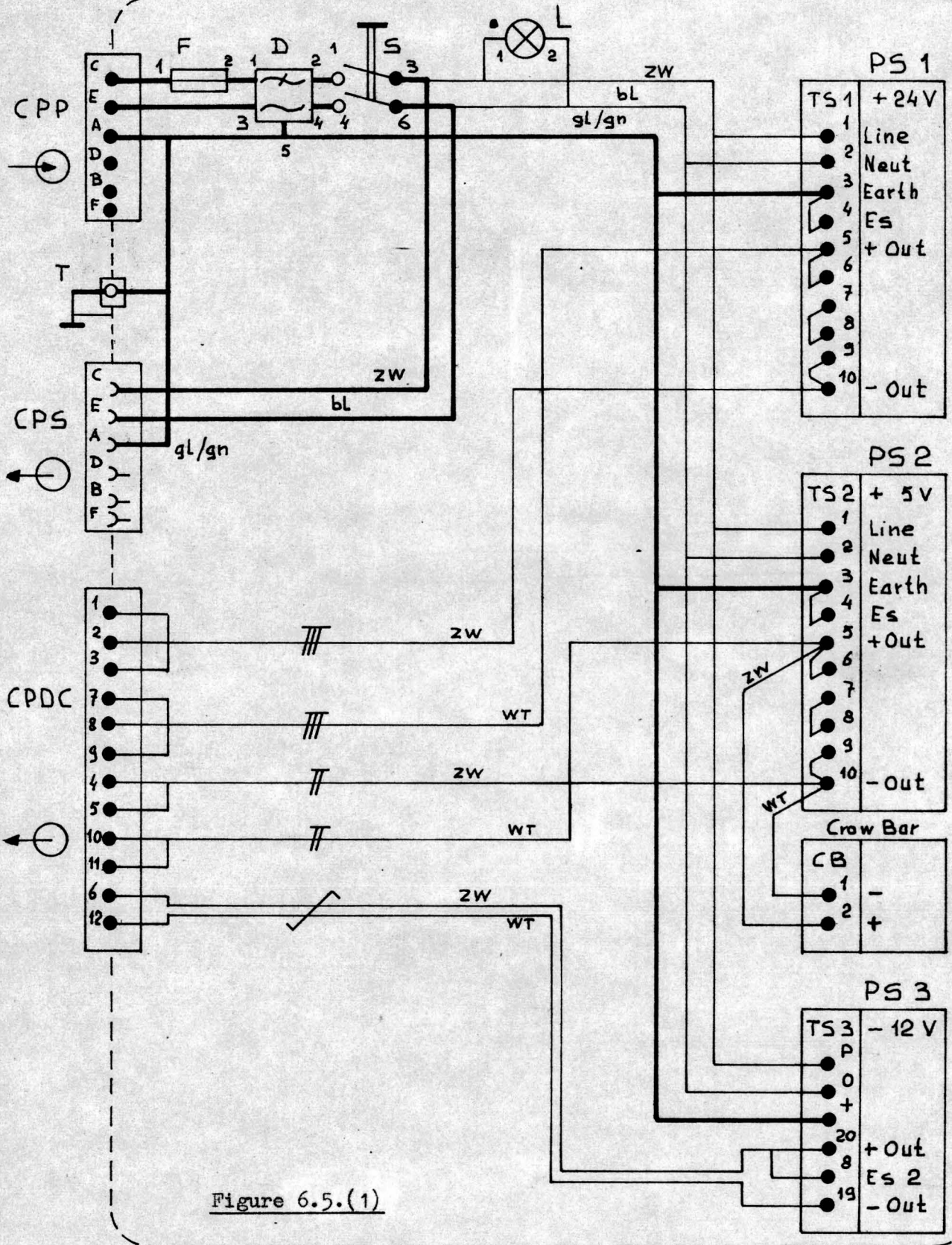

Figure 6.5.(1)

status	supers.doc.no.	dept. Prod.Planning
		author
N.V. PHILIPS - ELECTROLOGICA I.G. Peripheral Equipment		date 71-07-09
		page 6-25

ENGINEERING SPECIFICATION X 1210

doc.no.
reg.no. CNO/70/03005/523
distribution

All rights strictly reserved. Reproduction or issue to third parties in any form whatsoever is not permitted without written authority from the proprietor.

Eigendom van:
N.V. PHILIPS - ELECTROLOGICA
Apeldoorn
Nederland

Alle rechten uitdrukkelijk voorbehouden. Vermenigvuldiging of mededeling aan derden, in welke vorm ook, is zonder schriftelijke toestemming van eigenaar niet geoorloofd.

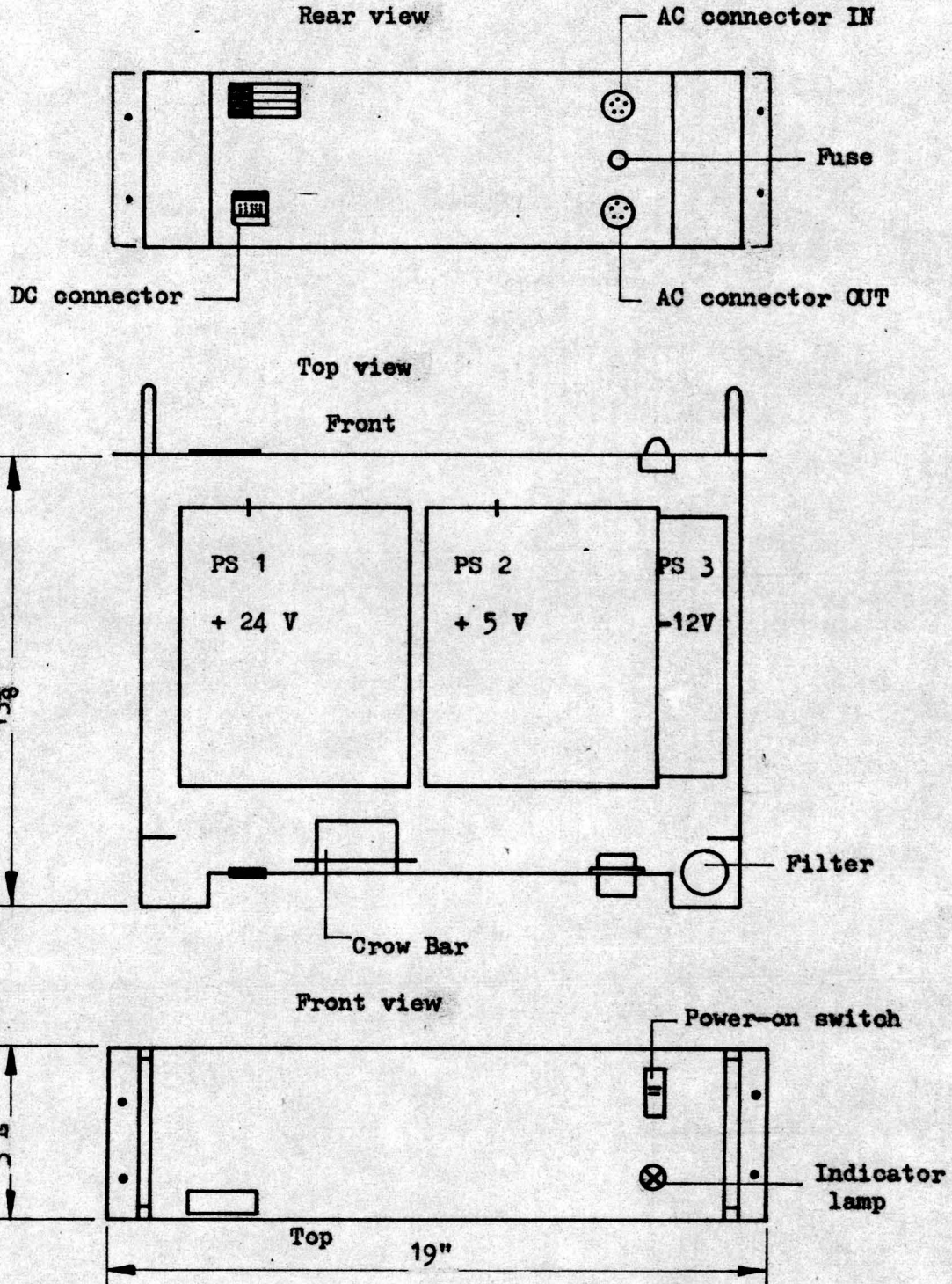

Figure 6.5.(2)

status	supers.doc.no.	dept. Prod.Planning
		author
N.V. PHILIPS - ELECTROLOGICA I.G. Peripheral Equipment		date 71-07-09
		page 6-26

ENGINEERING SPECIFICATION X 1210

doc.no.

reg.no.

CNO/70/03005/523

distribution

6.6. Tester module

Contents

6.6.1 Introduction

6.6.2 Operation

6.6.3 Technical characteristics

All rights strictly reserved. Reproduction or issue to third parties in any form whatever is not permitted without written authority from the proprietors.

Eigendom van: Property of
N.V. PHILIPS - ELECTROLOGICA
Apeldoorn Nederland

Alle rechten uitsluitend voorbehouden. Vermenigvuldiging of mededeling aan derden van het schriftelijke toestemming van eigenaars niet geoorloofd.

status		supers doc.no.	dept. Prod.Planning
			author
		N.V. PHILIPS - ELECTROLOGICA I.G. Peripheral Equipment	date 71-07-09
			page 6-27

6.6.1 Introduction

A reserved location in the electronics rack is provided for inserting a test module XMX 1408. The test module supplies positioning and selection commands to the X 1210 to enable positioning and selection of the heads. It is possible with this tester module to position the heads to the reference track of the C.E. cartridge. The test module obtains all signals and power from the disk drive.

6.6.2 Operation

The operators panel is provided with the following switches and indicators.

- 1 switch ON-OFF
- 8 switches CYLINDER DIFFERENCE
- 1 switch STEP-AUTOMATIC
- 1 switch FORWARD-REVERSE
- 1 switch GO-STOP
- 1 switch RETURN TO ZERO
- 1 switch CONTINUOUS-NORMAL ACCESS
- 1 switch HEAD SELECT
- 1 lamp ON CYLINDER

Note: Before installing or removing the test module, switch off all power supplied to the disk drive.

6.6.2.1 ON-OFF switch

Position "ON" means: the disk drive has ON-LINE Status and communicates with the Control Unit. Commands given by the test module do not interfere with normal operation. The test module may remain in the electronics rack.

Position "OFF" means: the disk drive is OFF-LINE and communicates with the test module.

The interface lines to the Control Unit are not switched off by the "OFF" position of the test module.

Therefore in order to have proper operation of the test module the Control Unit or Mono Disk exerciser XMX 1409 are not allowed to send commands.

Start/stop sequences can not be initiated by the test module. This has to be done by the START/STOP switch on the front of the disk drive. The test module is not operable during START/STOP sequences. When the START sequence has been finished the test module gives following possibilities by means of switch programming.

status	supers.doc.no.	dept. Prod.Planning
		author
	N.V. PHILIPS - ELECTROLOGICA I.G. Peripheral Equipment	date 71-07-09
		page 6-28

6.6.2.2 CYLINDER DIFFERENCE switches

These switches, on the panel indicated as switches "CODE 0 CODE 7", control the number of steps the positioner will make, as follows:

$$0 = 2^0 \text{ means 1 step}$$

$$1 = 2^1 \text{ means 2 steps}$$

$$7 = 2^7 \text{ means 128 steps}$$

Combinations of these switches enable the heads to reach every track on the disk.

6.6.2.3 STEP-AUTOMATIC switch

By means of this switch indicated on the panel as STEP-AUTOM, a positioning action can be executed at normal speed or with a stepfrequency of about 1,6 Herz, when the switch is in position STEP.

6.6.2.4 FORWARD-REVERSE switch

This switch "FOR-REV" commands the positioner to move the heads as controlled by cylinder differences switches in forward (towards center of the disk) or reverse direction.

6.6.2.5 CONTINUOUS-NORMAL ACCESS switch

This switch, "CA-NORM" on the panel, starts a program as follows:
 position C.A.- the heads start moving in forward direction as commanded by the cylinder difference switches
 - after execution of this movement, the heads move back to the starting point and the whole sequence starts again and is repeated continuously

6.6.2.6 GO-STOP switch

The positioning action is programmed by the following switches:

Switches "CODE 0 CODE 7"
 Switch "STEP-AUTOM"
 Switch "FOR-REV"
 Switch "CA-NORM"

When the GO-STOP switch is set to the "GO" position, it initiates the desired operation.

status		supers doc.no.	dept	Prod.Planning	
			author		
		N.V. PHILIPS - ELECTROLOGICA		date	71-07-09
		I.G. Peripheral Equipment		page	6-29

When the GO-STOP switch is in:

position "GO" - The test module simulates communication between control unit and disk drive. Switching to position "GO" equals the interface functions difference select, control select = "START SEEK". It is advised not to change positioning program during "GO" status. Reprogramming should be executed in "STOP" position.

position "STOP" - During positioning action switching to position "STOP" has following results:

- Switch "STEP-AUTOM" in "STEP" position; Positioning action is stopped immediately within 1 step range.
- Switch "STEP-AUTOM" in "AUTOM" position; Positioning action is stopped after execution of the chosen number of steps.

The following switches are not controlled by the GO-STOP switch.

6.6.2.7 HEAD SELECT switch

This switch enables the disk drive to select one of both heads, when the switch is in:

- Position "HEAD 00", the lower head will be selected
- Position "HEAD 01", the upper head will be selected

6.6.2.8 RETURN TO ZERO switch

When this switch is in position "RTZ" a return to zero action (return to track 000) is executed.

It is advised not to set switch "RTZ" in "RTZ" position and switch "GO-STOP" in "GO" position simultaneously.

6.6.2.9 ON CYLINDER indicator.

This indicator monitors the interface On Cylinder signal and will light when this signal is active.

status		supers doc.no.	dept. Prod.Planning
			author
		N.V. PHILIPS - ELECTROLOGICA I.G. Peripheral Equipment	date 71-07-09
			page 6-30

All rights strictly reserved. Reproduction or issue to third parties in any form whatever is not permitted without written authority from the proprietors.

Eigendom van: Property of
N.V. PHILIPS - ELECTROLOGICA
Apeldoorn Nederland

Alle rechten uitdrukkelijk voorbehouden. Vermenigvuldiging of mededeling aan derden, in welke vorm ook, is zonder schriftelijke toestemming van eigenares niet geoorloofd.

ENGINEERING SPECIFICATION X 1210

doc.no.

reg.no.

CNO/70/03005/523

distribution

6.6.3 Technical characteristics

The test module is supplied in a carrying case, which protects the module against damage and makes it easy to transport.

Weight of the module is approximately kg

Overall dimensions of the module are:

width	mm
height	mm
depth	mm

Note:

When also the mono disk exerciser XMX1409 is connected to the disk drive, the exerciser shall be off-line (function switch in read/write mode) otherwise the test module will not operate.

status		supers doc.no.	dept. Prod. planning
			author
		N.V. PHILIPS - ELECTROLOGICA	date 71-07-09
		I.G. Peripheral Equipment	page 6-31

ENGINEERING SPECIFICATION X 1210

doc.no.

reg.no.

distribution

6.7 Mono Disk Exerciser

Contents

- 6.7.1 Introduction
- 6.7.2 Operation
- 6.7.3 Technical characteristics

All rights strictly reserved. Reproduction or use in any form whatsoever is not permitted without written authority from the proprietors.

Eigendom van: Property of
N.V. PHILIPS - ELECTROLOGICA
Apeldoorn Nederland

Alle rechten uitdrukkelijk voorbehouden. Vermengvuidiging of mededeling aan derden, in welke vorm ook, is zonder schriftelijke toestemming van eigenares niet geoorloofd.

status		supers doc.no.	dept. Prod. planning
			author
		N.V. PHILIPS - ELECTROLOGICA Peripheral Equipment Division	date 71-07-09
			page 6-32

ENGINEERING SPECIFICATION X 1210

doc.no.

reg.no.

distribution

6.7.1 Introduction

The XMX 1409 mono disk exerciser is capable of operating the mono disk drive X1210. This portable exerciser therefore facilitates servicing of the disk drive without using the computer or control unit. The safety circuits can be tested under operation by simulating unsafe conditions. The operation is divided in seek operations and write, read and verify operations and therefore makes it possible to trace failures in certain parts of the mono disk drive. Instructions are given by means of toggle switches. Status signals are indicated by lamps.

6.7.2 Operation

The exerciser operates in one of the function modes, either write/read or seek mode. The switches and indicators are shown in fig. 6.7 (1).

6.7.2.1 Write/Read Operation

When the function switch WRITE/READ - POS is in the WRITE/READ position, the upper and middle, at the right, row of switches and indicators on the front panel are operative. The functions of these controls and indicators are as follows; from left to right.

- Head Selection

The HEAD switch indicates which of both heads in the mono disk drive will be selected when the SELECT push button is actuated. The upper head is selected when the switch is in upper position (1).

- Write Operation

When the switch is in WRITE position, the exerciser writes one track during one complete revolution of the disk. The data recorded is set by the BIT PATTERN switches. With these switches a word of 8 bits can be selected. However, the first being always a "1".

- Read and Verify Operation

The recorded bit pattern will be read when the switch is in READ position. The characters read from the disk drive will be compared with the selected BIT PATTERN. The FIRST "1" DETECTED indicator will light to indicate that the synchronising bit in the pattern "1" is detected and the read operation starts. When an error is detected in the bit pattern the READ FAULT COUNTER indicators will light and display one error on a track of the disk. When more bit errors are found on a track, they will be counted and displayed as one single error. The STATUS indicators READY, ON CYL and UNSAFE will show the status of the corresponding interface lines, independent of the function switch position.

All rights strictly reserved. Reproduction or issue to third parties in any form whatever is not permitted without written authority from the proprietors.

Eigendom van: N.V. PHILIPS - ELECTROLOGICA Apeldoorn
Property of: N.V. PHILIPS - ELECTROLOGICA Nederland

Alle rechten uitsluitend voorbehouden. Vermenigvuldiging of mededeling aan derden, in welke vorm ook, is zonder schriftelijke toestemming van eigenaar niet geoorloofd.

status		supers doc.no.	dept. Prod. planning
			author
		N.V. PHILIPS - ELECTROLOGICA Peripheral Equipment Division	date 71-07-09
			page 6-33

ENGINEERING SPECIFICATION X 1210

doc.no.
reg.no.
distribution

When the WRITE and READ switches are both in the upper position, the exerciser will alternatively write one track, read and verify the recorded track during the next disk revolution and start again with writing during the following revolution.

6.7.2.2 Seek Operation

The exerciser is able to position the heads when the function switch is in POS position. The number of steps the heads will move can be preset with the DIFFERENCE switches. Combinations of these switches enable the heads to position over each track. The way the heads will move can be set with the ACCESS switches. When the switch NORMAL-CONT is in NORMAL position, the heads will move in forward or reverse direction according with the position of the FORW-REV switch. The positioning action begins when the START push button is pressed. In the CONT position the FORW-REV switch is inactive. The heads will move continuously when the START button is pressed. They move the selected number of steps (difference) first in forward direction and when the track is reached, the heads go back the same number of steps, and the cycle starts again. This oscillatory positioning between two tracks will end when the STOP button is pressed. The heads will go to track 000 when the RETURN TO ZERO button is pressed. This button overrides the other seek commands of the two switches.

6.7.2.3 Output jacks

At the right side of the panel, six output jacks are situated, providing test points. Three jacks provide the inverted interface signals 'on cylinder', 'index' and 'sector'. One jack, SEEK COMM, provides a triggering signal for oscilloscopes and one jack is connected to ground.

6.7.3 Technical Characteristics

The mono disk exerciser is provided with a cable, length 2,3m to interconnect the exerciser in the cable circuit. The necessary single +5V DC 0,8A is supplied by the power supply unit XMX 1407. The weight of the exerciser is approximately 6 kg and overall dimensions 330 x 320 x 160 mm.

Note: The mono disk exerciser XMX 1409 will not operate in combination with a Taster Module XMX 1408 when this module is active.

All rights strictly reserved. Reproduction or issue to third parties in any form whatever is not permitted without written authority from the proprietors.

Property of
N.V. PHILIPS - ELECTROLOGICA
Nederland
Eigendom van:
N.V. PHILIPS - ELECTROLOGICA
Apeldoorn

Alle rechten uitdrukkelijk voorbehouden. Afdrukking of mededeling in welke vorm ook, is zonder schriftelijke toestemming van eigenaars niet geoorloofd.

status		supers doc.no.	dept. Prod. planning
			author
		N.V. PHILIPS - ELECTROLOGICA	date 71-07-09
		Peripheral Equipment Division	page 6-34a

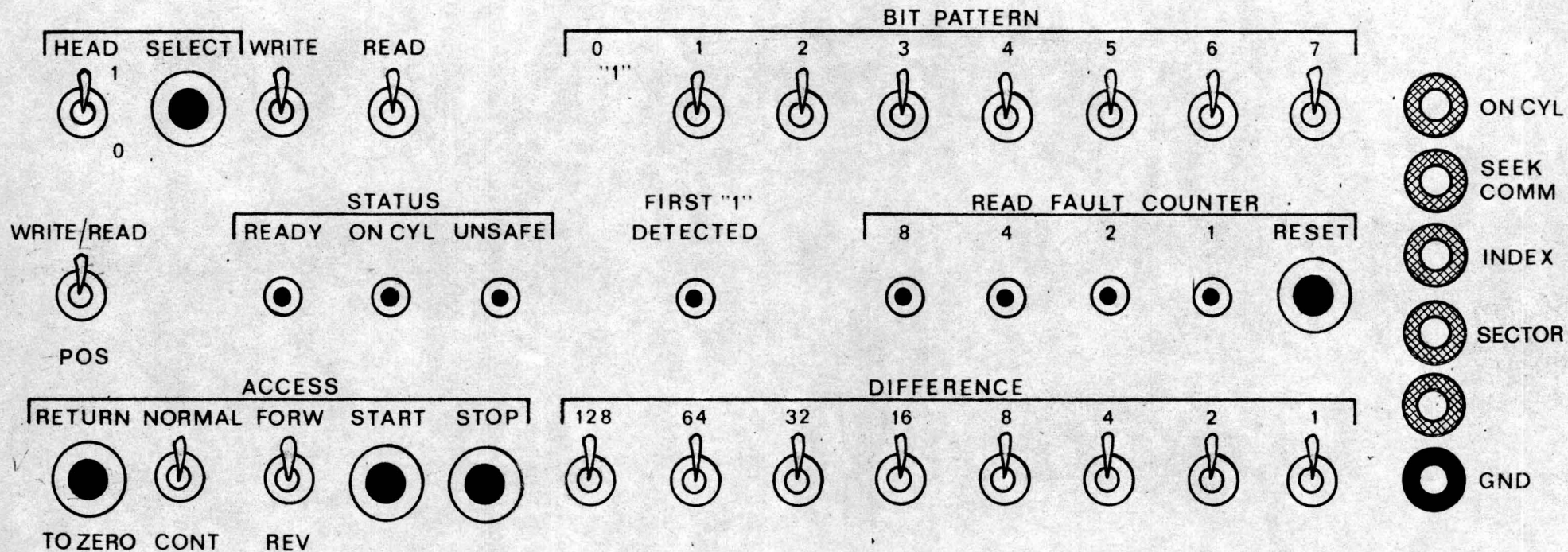

XMX 1409

MONO DISK EXERCISER

PHILIPS



ENGINEERING SPECIFICATION X 1210

doc.no.

reg.no.

CN070/03005/523

distribution

6.8 C.E. Cartridge

6.8.1 Description

All rights strictly reserved. Reproduction or issue to third parties in any form whatever is not permitted without written authority from the proprietors.

Eigendom van: Property of
N.V. PHILIPS - ELECTROLOGICA
Apeldoorn Nederland

Alle rechten uitdrukkelijk voorbehouden. Vermenigvuldiging of mededeling aan derden, in welke vorm ook, is zonder schriftelijke toestemming van eigenares niet geoorloofd.

status		supers doc.no.	dept. Prod. planning
			author
N.V. PHILIPS - ELECTROLOGICA Peripheral Equipment Division			date 71-07-09
			page 6-35

ENGINEERING SPECIFICATION X 1210

doc.no.
reg.no. CNO70/03005/523
distribution

6.8.1 Description

The Customer Engineering cartridge XMX 1410 is physically the same as the standard cartridge XMX 1416. On track 100 however, a pattern is precisely pre-recorded, on both surfaces of the disk. The two heads can be precisely aligned on track. The beginning of the pattern is also suitable to adjust the index/sector sensor to give the proper time relation between the index signal and the data read by the heads.
It is advised to control the heads with the tester module XMX 1408 to avoid accidental writing on the reference track.

All rights strictly reserved. Reproduction or use in any form whatsoever is not permitted without written authority from the proprietors.

Property of
N.V. PHILIPS - ELECTROLOGICA
Nederland
Apeldoorn

Alle rechten uitdrukkelijk voorbehouden.
Vernieuwgeving of mededeling aan derden in welke vorm ook, is zonder schriftelijke toestemming van eigenaars niet geoorloofd.

status		supers doc.no.	dept. Prod. planning
			author
		N.V. PHILIPS - ELECTROLOGICA Peripheral Equipment Division	date 71-07-09
			page 6-36

ENGINEERING SPECIFICATION X 1210

doc.no.
 reg.no. CNO70/03005/523
 distribution

6.9 Handbook

A handbook providing operating and maintenance instructions for the X 1210 and the options, is available. Description and theoretical information is provided to give operating and maintenance personnel a better understanding of the equipment. The handbook is divided into volumes as follows:

- Volume 1 - Introduction
 This volume contains a brief description of equipment, purpose and how it performs its mission and a tabulation of technical characteristics.
- Volume 2 - Operation
 Volume 2 contains normal and emergency operating procedures, and operator maintenance instructions.
- Volume 3 - Device logic
 This volume contains schematic diagrams of the logic circuits and a description of the individual circuits function.
- Volume 4 - Not applicable.
- Volume 5 - Electronics
 In this volume the functioning of the special electronic circuits and power supplies are described.
- Volume 6 - Mechanics
 This volume describes the mechanical parts and how they function.
- Volume 7 - Maintenance
 Volume 7 contains procedures and information to isolate a malfunction to an assembly and instructions for corrective and preventive maintenance.
- Volume 8 - Parts List
 This volume gives an illustrated parts breakdown of the X 1210 and options.
- Supplements These contain instructions for installation, unpacking and a recommended spare parts list.

All rights strictly reserved. Reproduction or issue to third parties in any form whatever is not permitted without written authority from the proprietors.

Eigendom van: N.V. PHILIPS-ELECTROLOGICA Apeldoorn
 Property of: NEDERLAND

Alle rechten uitdrukkelijk voorbehouden. Vermengvuldiging of mededeling aan derden, in welke vorm ook, is zonder schriftelijke toestemming van eigenaars niet geoorloofd.

status		supers doc.no.	dept Prod. planning
			author
		N.V. PHILIPS - ELECTROLOGICA I.G. Peripheral Equipment	date 71-07-09
			page 6-37

ENGINEERING SPECIFICATION X 1210

doc.no.

reg.no.

CN070/03005/523

distribution

7. Applicable documents

7.1 Safety requirements

The X 1210 mono disk drive and options will comply with IECMA standard nr. 22:

- Electrical safety requirements for data processing machines, dated 12th June, 1969.

7.2 Interference

The X 1210 mono disk drive and options will comply with the N-curve of VDE 0871 with respect to Mains Radio Interference Suppression.

All rights strictly reserved. Reproduction or issue to third parties in any form whatever is not permitted without written authority from the proprietors.

Eigendom van: Property of
N.V. PHILIPS - ELECTROLOGICA
Apeldoorn Nederland

Alle rechten uitdrukkelijk voorbehouden. Vermogensvuidiging of mededeeling aan derden, in welke vorm ook, is zonder schriftelijke toestemming van eigenares niet geoorloofd.

status		supers doc.no.	dept. Prod. planning
			author
		N.V. PHILIPS - ELECTROLOGICA I.G. Peripheral Equipment	date 71-07-09
			page 7-1

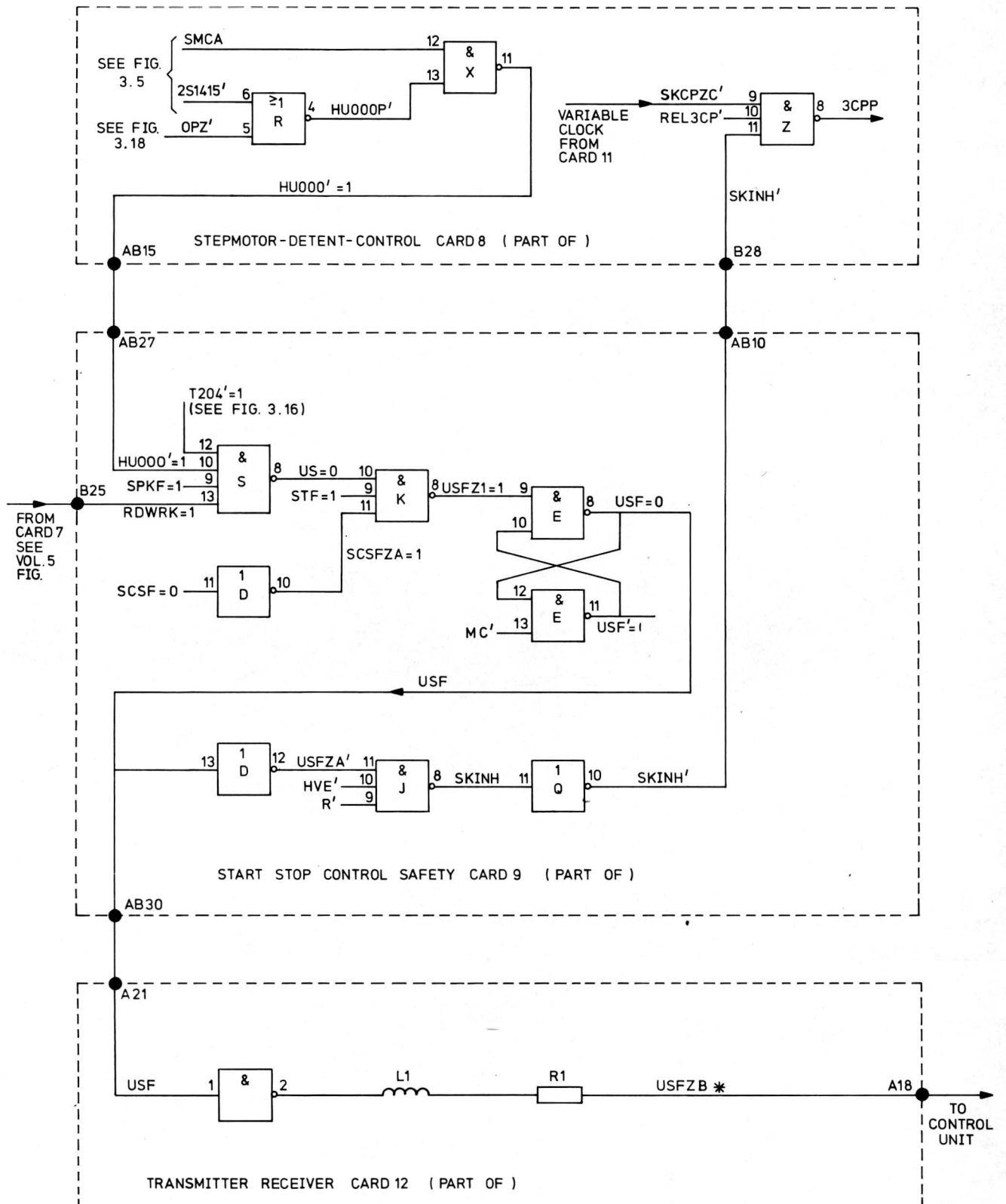

NOTE :- LOGIC STATES SHOWN ARE FOR SAFE CONDITIONS.

FIG. 3.36 THE UNSAFE CONDITIONS

CARDS																															
CARD PIN NO.	1				2				3				8				9				11				12				CARD PIN NO.		
	TO	A	B	TO	TO	A	B	TO	TO	A	B	TO	TO	A	B	TO	TO	A	B	TO	TO	A	B	TO	TO	A	B	TO			
1	CP8/4		005	CP8/4 2/A1	CP8/4 1/B1		005	CP8/5 3/A1	CP8/5 2/B1		005	CP8/5 4/A1	7/B1		005	9/A1	8/B1		005	11/A1	9/B1		005	12/A1	11/B1		005		1		
2	CP8/10		000	CP8/10 2/A2	CP8/10 1/B2		000	CP8/11 3/A2	CP8/11 2/B2		000	CP8/11 4/A2	CP7/99 7/B2		000	CP7/101 9/A2	8/B2		000	11/A2	9/B2		000	12/A2	CP7/9 11/B2		000		2		
3	2/A3 CP8/2		024	2/B3 CP8/3(2)	1/A3 CP8/13(2)		024	1/B3	9/A24		HVE'		1/A11		CD5E'				SPKF		8/B29	3CP	SKCPZB	10/A17	10/A30	TBUS 6'	BUS 6	11/A11	3		
4	2/A4 CP8/2(2)		024	2/B4 CP8/3	1/A4 CP7/48		024	1/B4	9/B6		PME'		1/A13		CD7E'		12/A22 10/A9		IP	SPKM		10/A3	TFF	TCP'	10/A4	CP7/4	BUS 5*'	BUS 5	11/A19	4	
5	2/A5 CP8/2		024	2/B5 CP8/3	1/A5 7/A14 CP10/22		024	1/B5 CP10/22	9/B28		STF'		2/A13		CD3E'		3/A9 10/A19 12/B21		HØD		8/A22	DTCZ0'	OCP	7/A19	11/A12	BUS 4	TBUS 5'	10/A29	5		
6									9/A11		USFZA'		2/A14		CD4E'		CP7/94		ISI*	PME'	3/A4	10/A6	TRZF'	TAG 3	12/B12	10/A28	TBUS 4'	BUS 4*'	CP7/2	6	
7	2/A7 CP8/8(2)		000	2/B7 CP8/9(2)	1/A7		000	1/B7			000				000				000				000		CP7/1 CP7/3		000		CP7/7 CP7/13	7	
8	2/A8 CP8/8		000	2/B8 CP8/9	1/A8		000	1/B8	9/B21		EXD'		2/A11		CD1E'		7/A23 12/B19 10/B27		HØT	HØT'	10/A5	9/A25	RTZFZ1'	EREN'	6/A29 7/A31	11/A17	BUS 7	BUS 6*'	CP7/8	8	
9	2/A9 CP8/8		000	2/B9 CP8/9	1/A9		000	1/B9	9/A5		HØD'		1/A12		CD2E'		12/B22		SP		8/A24	2CP	SKINH'	9/A10	CP7/14	BUS 7*'	TBUS 7'	10/A31	9		
10													1/A12		CD6E'		8/B28 11/B9		SKINH'		12/A16	TAG 1		6/A4 7/A24	WRDA	WRDA*'	CP7/10	10			
11	8/A3		CD5E'		8/A8		CD1E'						1/A14		CD8E'		3/A6 11/B31		USFZA'		12/B3	BUS 6		CP7/16	RDDA*'	RDDA	5/A28	11			
12	8/A10		CD6E'		8/A9		CD2E'										8/B31		CLCY'		12/A5	BUS 4	SCSRZ0'	CP7/20	TAG 3*'	TAG 3	11/B6	12			
13	8/A4		CD7E'		8/A5		CD3E'				000		CP7/51		000		CP7/53 CP7/63		000				000		CP7/15 CP7/21	000		CP7/31 CP7/19	13		
14	8/A11		CD8E'		8/A6		CD4E'								SMCZ0'		7/A18		ISØ				L6SF'	CP7/22	RESR*'	RESR		14			
15	8/A16		DETD2E'		8/A18		DETD1E'						9/B27		HU000'		CP7/76		RTØ*'					6/A9	TAG 2	TAG 2*'	CP7/28	15			
16													1/A15		DETD2E'		8/A19		T204			8/A25	REL3CP'		11/A10	TAG 1			16		
17													CP7/100		ØPZ*		CP7/54		R*			12/A8	BUS 7		CP7/34	TAG 1*'	TAG1M'	10/A14	17		
18													2/A15		DETD1E'							12/B28	BUS 1		CP7/40	USFZB*'	HØTZB*'	CP7/26	18		
19	CP10/16		C7P*	CP10/16	CP10/6		C3P*	CP10/6					9/A16		T204		CP7/60		SSD*'	SSU*'	CP7/57	12/B4	BUS 5		CP7/32	HØDZA*'	HØT	9/A8	19		
20	CP10/15		C7E*'	CP10/15	CP10/5		C3E*'	CP10/5			000				000				000		CP7/58		000		CP7/41 CP7/39	000		CP7/33 CP7/27	20		
21	CP10/14		C6P	CP10/14	CP10/4		C2P*	CP10/4					CP7/52		HO200'		7/A8		SPZ	EXD'	3/A8	12/B27	BUS 3		9/A30	USF	HØD	9/A5	21		
22	CP10/13		C6E*'	CP10/13	CP10/3		C2E*'	CP10/3					11/A5		DTCZ0'		8/A27		SKCF			12/B25	BUS 2		9/A4	IP	SP	9/A9	22		
23	CP10/12		C5P	CP10/12	CP10/2		C1P*	CP10/2					9/B29	T000'	DLF'	11/A31	8/A31		RTRP'	CLF		6/A10 12/A30	BUS 0			REST	IPZA*'	CP7/38	23		
24	CP10/11		C5E*'	CP10/11	CP10/1		C1E*'	CP10/1					11/A9	2CP	DTT'		3/A3		HVE'	STF		8/A29	FWDF'		CP7/44	SPZA*'	REST*'	CP7/50	24		
25	CP10/18		C8P	CP10/18	CP10/8		C4P*	CP10/8					11/A16	REL3CP'	MC'	9/A29	11/A8		RTZFZ1'	RDWRK*	7/A22 CP7/90	7/A25	RDEN'	SEX'	10/A11	10/A24	TBUS 2'	BUS 2	11/A22	25	
26	CP10/20		DET2P	CP10/20	CP10/10		DET1P*	CP10/10			000				000		CP7/59		000				000		CP7/25 CP7/49	000		CP7/37 CP7/43	26		
27	CP10/19		DET2E*'	CP10/19	CP10/9		DET1E*'	CP10/9	CP10/21	9/A22		HVA*'	CP10/21	9/A22	SKCF	SKCFZ0'			HU000'		8/A15		L16F	TFWD'	10/A16	CP7/56	BUS 2*'	BUS 3	11/A21	27	
28	CP10/17		C8E*'	CP10/17	CP10/7		C4E*'	CP10/7	CP8/14		PMRA*'				DETF	SKINH'	9/A10	8/B30 10/A19		RTZF'	STF'	3/A5	10/A15	TREV'	WREN'	7/A27 6/A28	10/A25	TBUS 3'	BUS 1	11/A18	28
29									CP8/17		STLØN*'		11/A24		FWDF'	3CP	11/A3	8/B25 11/B30		MC'	T000'	8/A23	8/A30	SKCPZC	TOLM'	10/A12	CP7/62	BUS 1*'	TBUS1'	10/A22	29
30									CP8/16		USFLØN*'		11/A29		SKCPZC	RTZF'	9/A28	12/A21		USF			10/A8	TSKINH'	MC'	9/A29	11/A23	BUS 0	BUS 0*'	CP7/68	30
31									CP8/15 CP7/47		EXDLØN*'		9/A23		RTRP'	CLCY'	9/A12			SCSF			8/B23	DLF'	USFZA'	9/A11	10/A21	TBUS0'	BUS3*'	CP7/74	31
32											000				000				000				000		CP7/55 CP7/73	000		CP7/67 CP7/61	32		

FIG. 3-37 X1210 LOGIC CARD INTER-CONNECTIONS

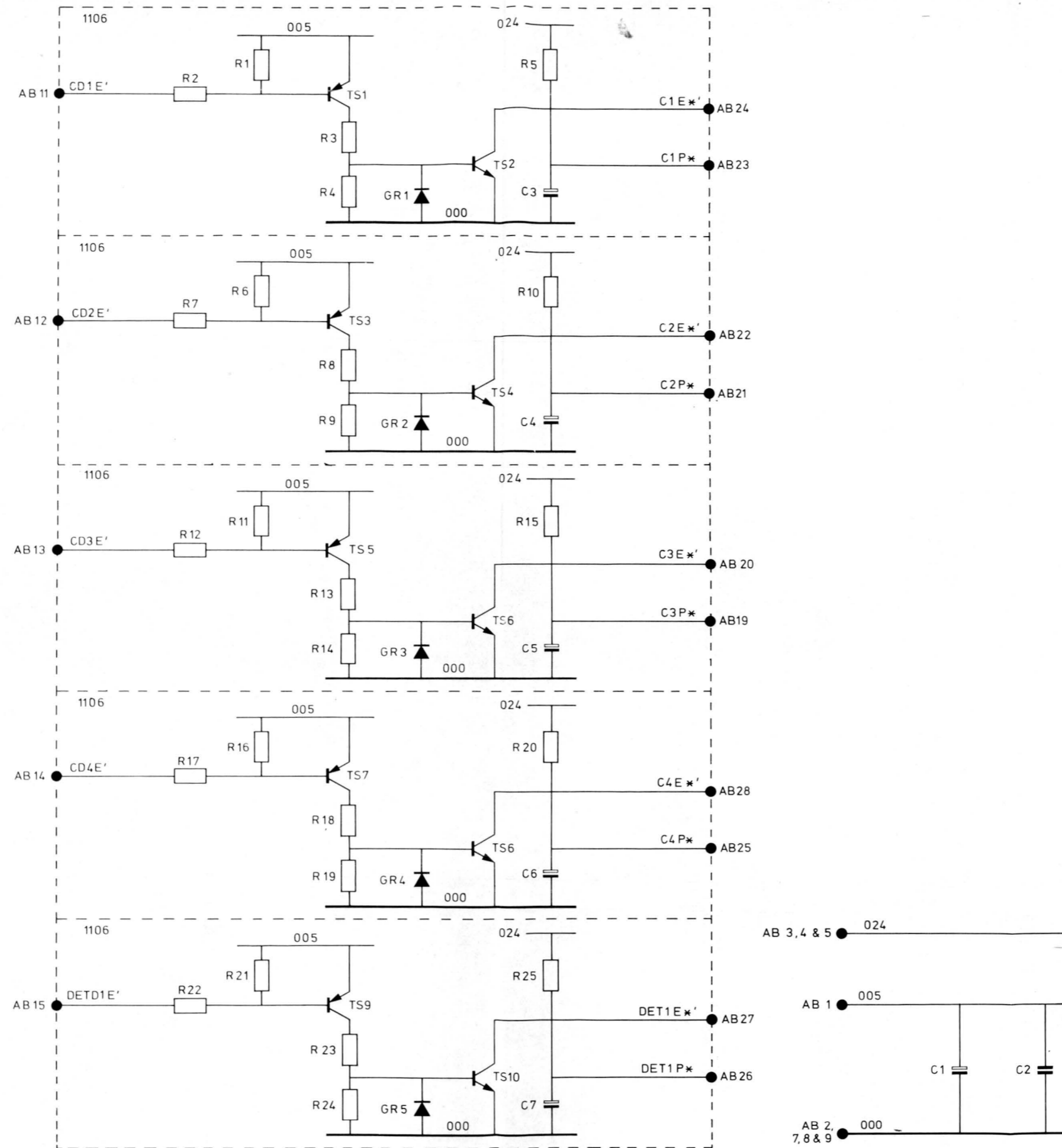

FIG.3-39 STEPMOTOR DETENT DRIVER CARD 2

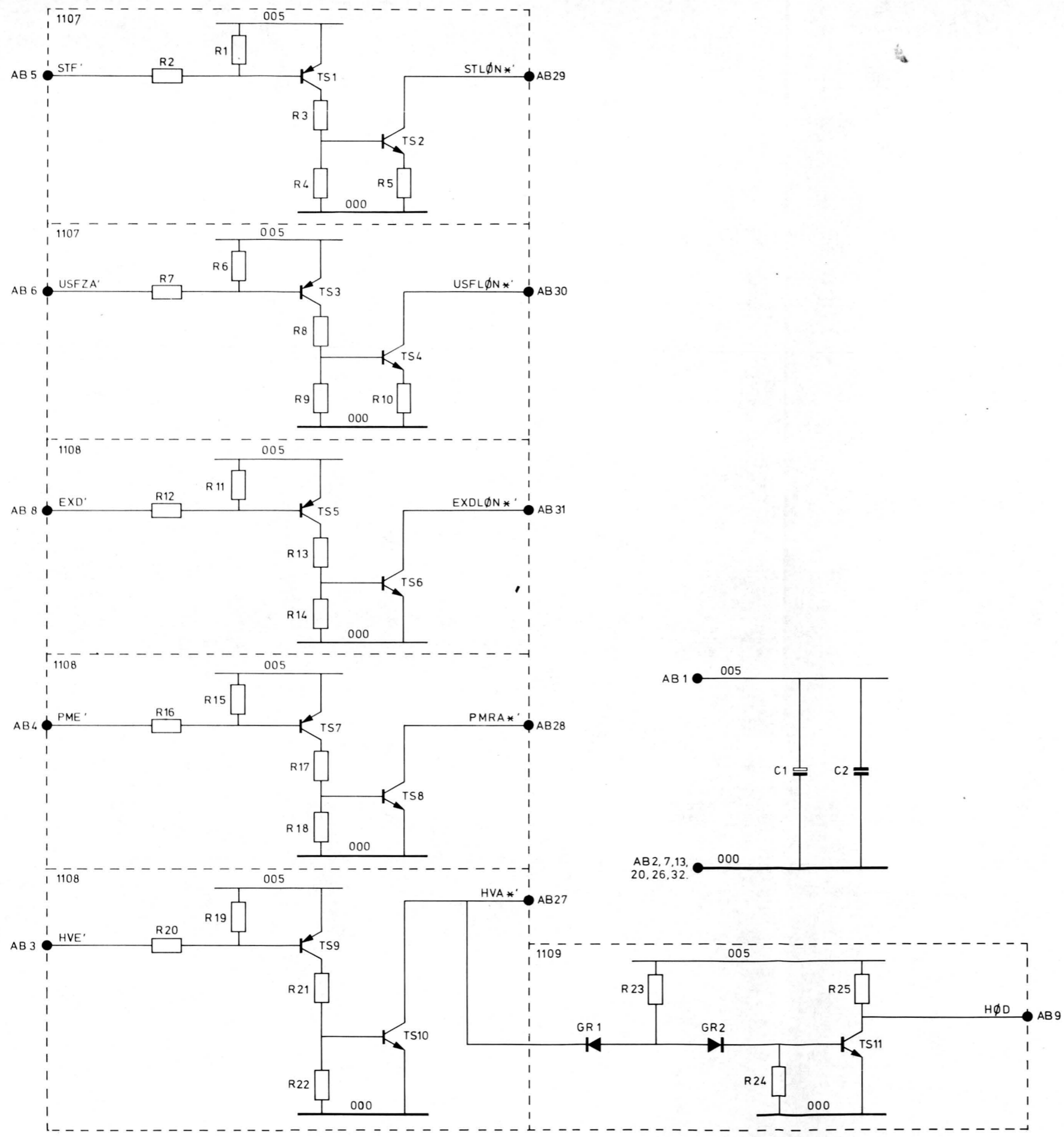

FIG.3.40 LAMP RELAY, VALVE DRIVER AND LEVEL SHIFTER CARD 3

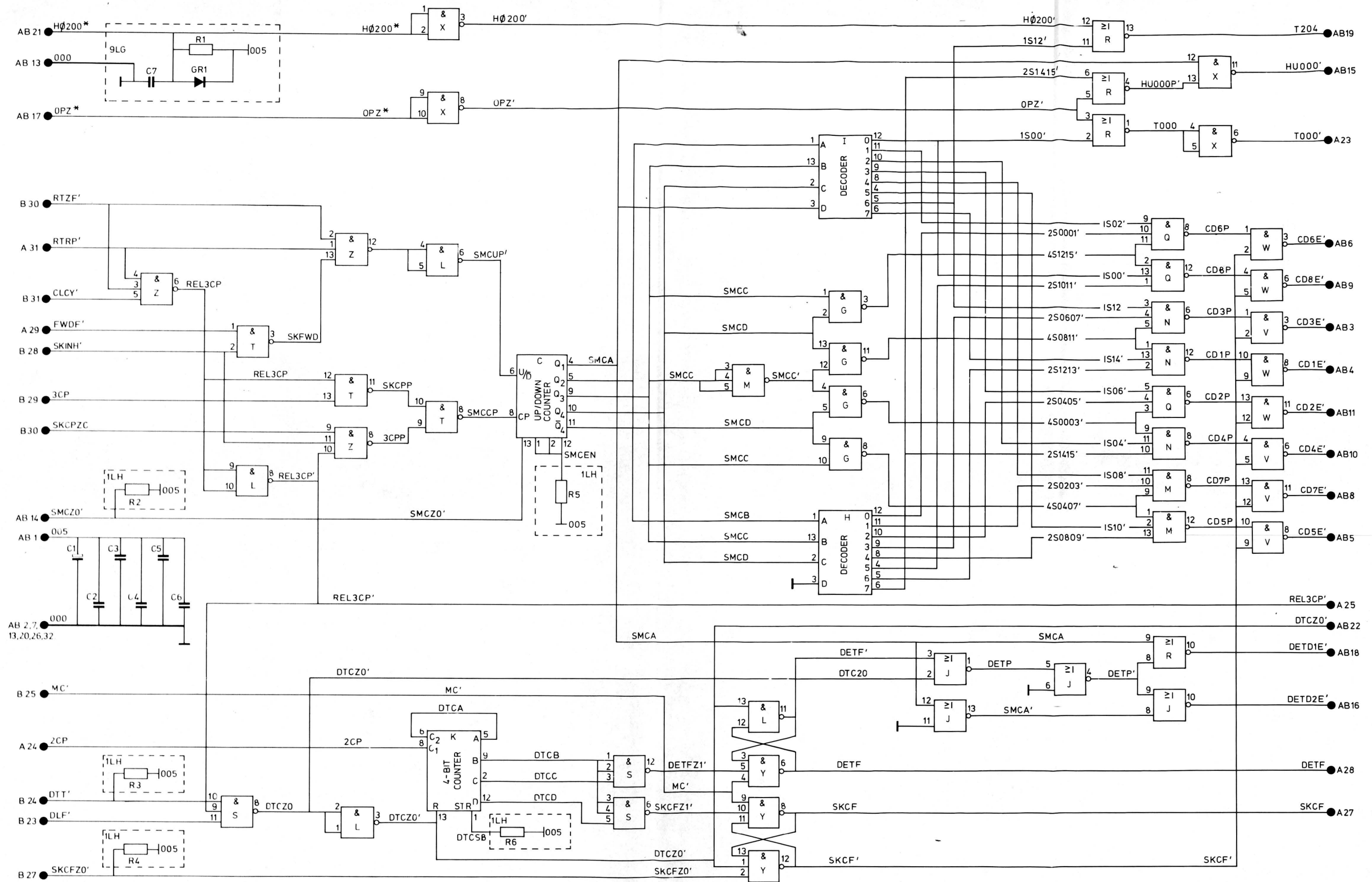

FIG. 3-41 STEPMOTOR DETENT CONTROL CARD 8

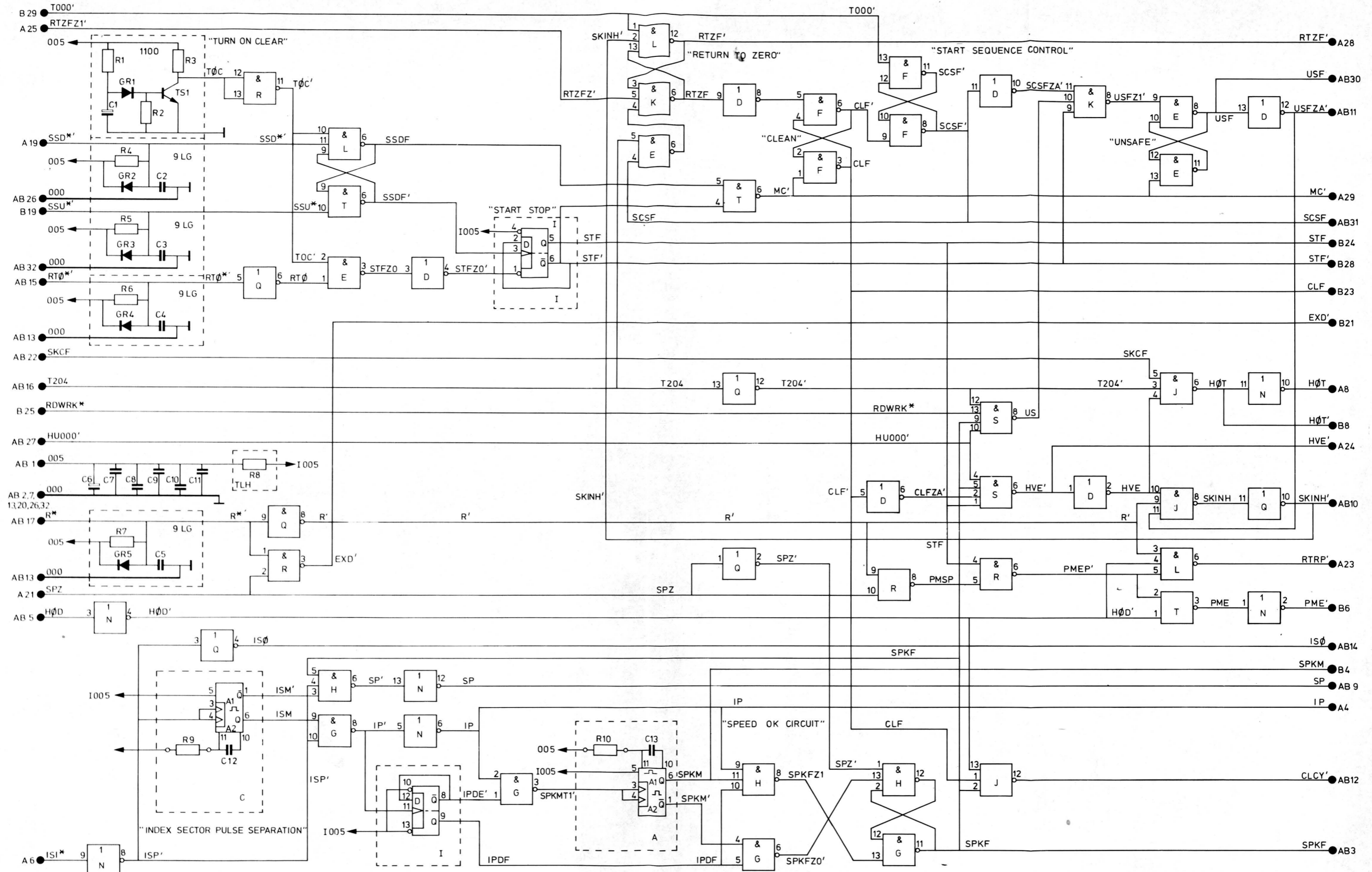

FIG. 3-42 START/STOP/SAFETY CONTROL CARD 9

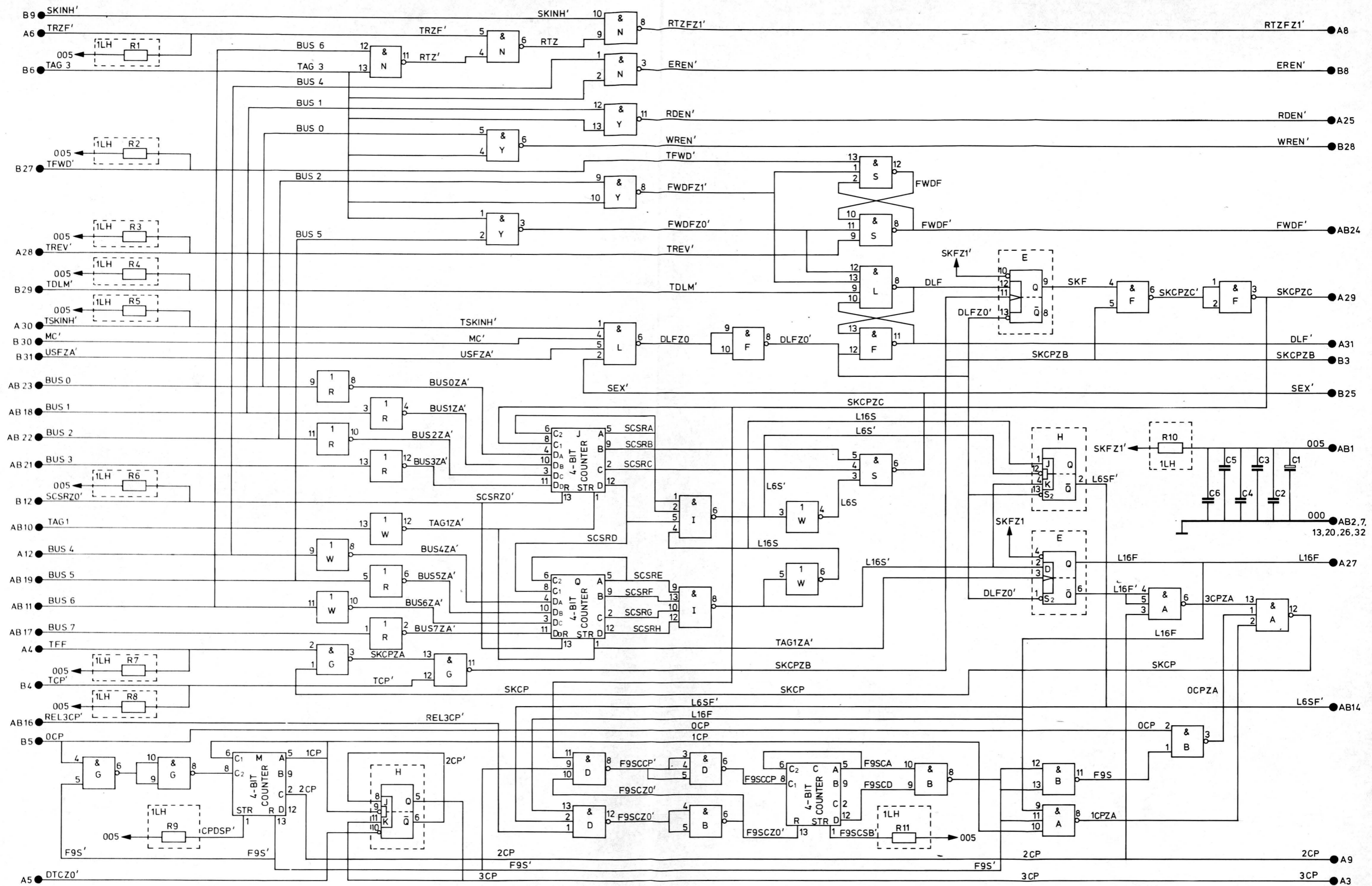

FIG. 3.43 REGISTER VARIABLE SPEED
CARD 11

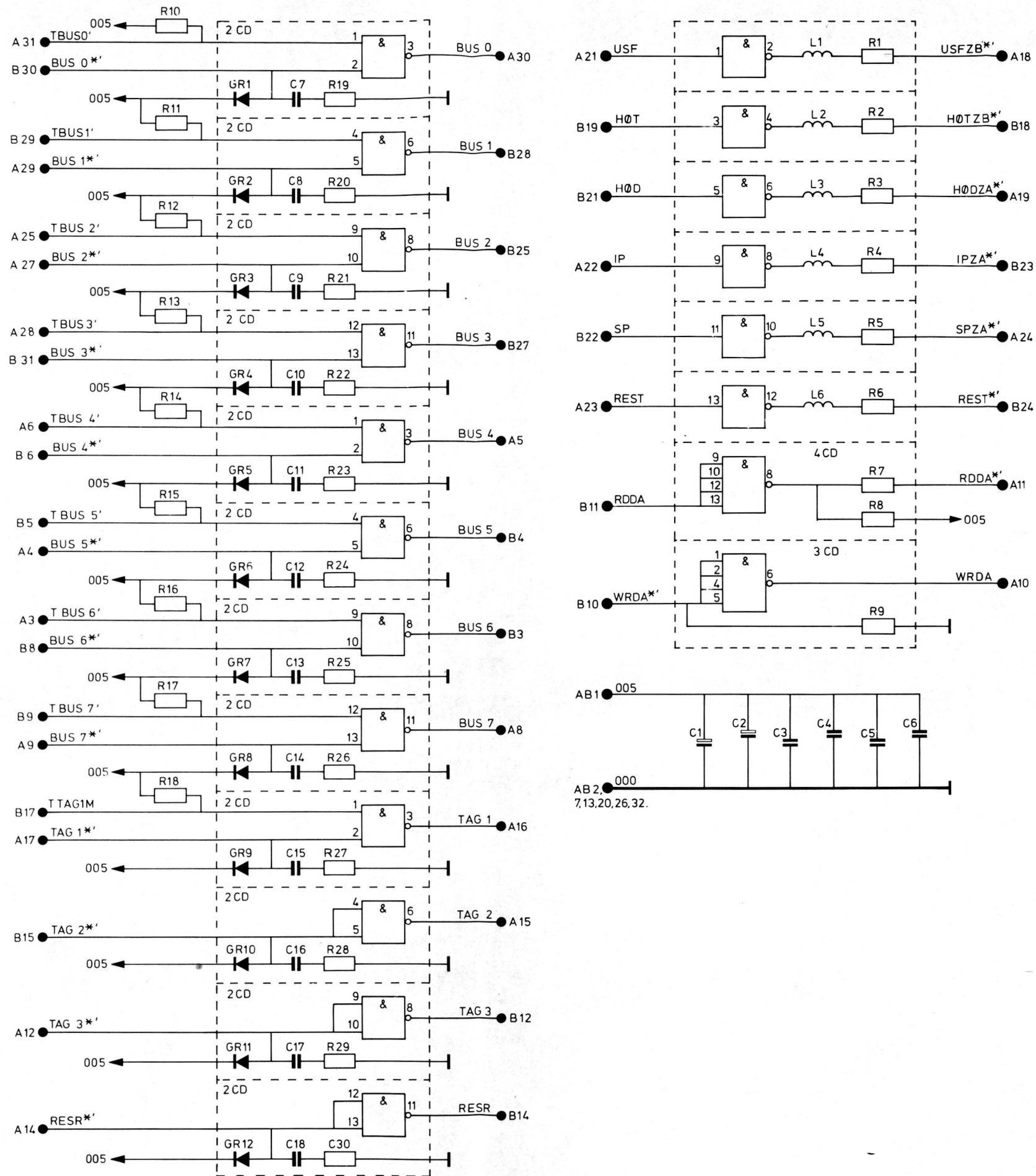

FIG. 3-44 TRANSMITTER/RECEIVER
CARD 12